



# **ATND1061LK**

# **ATND1061DAN**

Beamforming Array Microphone

---

## **User Manual**

### **- Main Unit Edition -**

English

# Table of Contents

<b>Safety precautions</b> .....	<b>5</b>
Battery caution .....	5
For customers in the USA .....	5
FCC Notice .....	5
For customers in Canada .....	6
ISED statement .....	6
<b>Installation precautions</b> .....	<b>7</b>
<b>Maintenance</b> .....	<b>8</b>
<b>Package contents</b> .....	<b>9</b>
<b>Part names and functions</b> .....	<b>11</b>
Microphone .....	11
ATND1061LK .....	11
ATND1061DAN .....	12
Indicator lamp .....	13
IR remote controller .....	14
How to change presets .....	14
<b>Installation</b> .....	<b>16</b>
Hard ceiling installation .....	16
Surface mounting .....	16
Flush mounting .....	21
Grid ceiling installation .....	27
Surface mounting .....	27
Flush mounting .....	33
Installation with VESA mount .....	41
Removing the microphone .....	42
Surface mounting .....	42
Flush mounting .....	43
<b>Connection procedure</b> .....	<b>45</b>
System connection examples .....	45
ATND1061LK (connecting only one unit) .....	45
ATND1061LK (connecting multiple units) .....	46
ATND1061DAN (single cable mode) .....	47
ATND1061DAN (split mode) .....	48
ATND1061DAN (connecting multiple units) .....	49
ATND1061DAN (single cable mode and analog I/O) .....	50
Connecting Euroblock connectors .....	50
GPI port .....	52
<b>Reset button</b> .....	<b>53</b>
Checking the network mode .....	53

# Table of Contents

Network reset .....	53
Factory reset .....	54
<b>Digital Microphone Manager .....</b>	<b>55</b>
<b>Audio-Technica LINK .....</b>	<b>56</b>
<b>Dante Controller (ATND1061DAN only) .....</b>	<b>57</b>
Dante channel list .....	57
Input (Dante Transmitter) .....	57
Output (Dante Receiver) .....	57
<b>Web Remote .....</b>	<b>58</b>
What is Web Remote? .....	58
What is Locate? .....	58
Recommended environment .....	58
OS for running Web Remote and Locate .....	58
Recommended web browsers for Web Remote .....	58
Preparation for Web Remote .....	59
Connecting the microphone with the control device .....	59
Setting up Locate .....	59
Launching Web Remote .....	60
Launch from Locate .....	60
Launch by directly specifying the IP address .....	60
Basic operations on Setting & Maintenance screen .....	60
General (System Settings) .....	62
Device Name .....	62
LED Settings .....	62
Dimmer Settings .....	62
Network (System Settings) .....	62
Network Configuration (ATND1061DAN only) .....	62
Dante & Audio Port Settings (ATND1061DAN only) .....	63
IP Control & Web Remote Port Settings .....	63
Allow Discovery .....	63
IP Control Settings .....	64
Utilities (System Settings) .....	64
Firmware Update .....	64
Reset All Settings to Default .....	65
Audio (Install Settings) .....	66
Beam CHs .....	66
Analog Input .....	66
DSP Mode .....	66
Auto Mix CH .....	67
Analog Output .....	67

## Table of Contents

Voice Lift CH .....	67
Dante Tx#6 Signal (ATND1061DAN only) .....	67
Camera .....	68
Device .....	68
Talk Setting .....	68
Silent Setting .....	68
Camera Preset .....	68
Presets .....	69
Presets .....	69
Exporting presets .....	69
Importing presets .....	70
Logging .....	71
System Info .....	71
Header .....	71
Displaying descriptions of errors .....	73
Presets .....	73
Saving presets .....	73
Recalling presets .....	74
<b>Function List .....</b>	<b>76</b>
<b>Troubleshooting .....</b>	<b>81</b>
<b>Dimensions .....</b>	<b>84</b>
ATND1061LK .....	84
ATND1061DAN .....	85
Surface mount adapter .....	86
Flush mount adapter .....	87
Flush mount cover .....	88
Tile bridge A .....	88
Tile bridge B .....	89
Tile bridge C .....	89
Assembly diagram of tile bridge for grid ceiling .....	90
<b>Specifications .....</b>	<b>91</b>
ATND1061LK .....	91
General .....	91
Microphone .....	91
Analog audio .....	91
Other .....	92
ATND1061DAN .....	92
General .....	92
Microphone .....	93
Analog audio .....	93

# Table of Contents

Other .....	94
<b>Polar pattern / Frequency response .....</b>	<b>95</b>
Polar pattern .....	95
Frequency response .....	95
<b>Trademarks .....</b>	<b>96</b>
<b>System diagram .....</b>	<b>97</b>

# Safety precautions

Although this product was designed to be used safely, failing to use it correctly may result in an accident. To ensure safety, observe all warnings and cautions while using the product.

The product is intended for commercial use, not for general use.

- Disconnect the product from a device if the product begins to malfunction, producing smoke, odor, heat, unwanted noise or showing other signs of damage. In such a case, contact your local Audio-Technica dealer.
- Do not disassemble, modify or attempt to repair the product to avoid electric shock, malfunction or fire.
- Do not subject the product to strong impact to avoid electric shock, malfunction or fire.
- Do not handle the product with wet hands to avoid electric shock or injury.
- Do not allow the product to get wet to avoid electric shock or malfunction.
- Do not put foreign matter such as combustible materials, metal, or liquid in the product.
- Do not cover the product with a cloth to avoid fire or injury by overheating.
- Keep the product out of the reach of small children. The product is not intended for use around children.
- Do not place the product near fire to avoid an accident or the product catching fire.
- Do not put the product in a location where it is exposed to direct sunlight, near heating devices, or in places with high temperatures, high humidity, or high concentrations of dust to avoid electric shock, fire, malfunction, etc.
- Keep away from a fire to avoid deformation or malfunction.
- Do not use chemicals such as benzine, thinner, electrical contact cleaner, etc. to avoid deformation or malfunction.

## Battery caution

- Keep batteries out of the reach of children.
- Observe correct polarity as marked.
- Do not expose the battery to excessive heat such as sunshine, fire or the like.
- Always consider the environmental issues and follow local regulations when disposing of batteries.
- Remove depleted battery immediately.
- Danger of explosion if battery is incorrectly replaced. Replace only with the same or equivalent type.
- Do not use rechargeable batteries.
- Do not use a leaking battery. If battery leakage occurs, avoid contact with skin. If contact occurs, immediately wash thoroughly with soap and water.
- If battery leakage comes into contact with your eyes, immediately flush with water and seek medical attention.

## For customers in the USA

### FCC Notice

#### Warning

This device complies with Part 15 of the FCC Rules. Operation is subject to the following two conditions: (1) This device may not cause harmful interference, and (2) this device must accept any interference received, including interference that may cause undesired operation.

## Safety precautions

### Caution

You are cautioned that any changes or modifications not expressly approved in this manual could void your authority to operate this equipment.

### Note

This equipment has been tested and found to comply with the limits for a Class B digital device, pursuant to part 15 of the FCC Rules. These limits are designed to provide reasonable protection against harmful interference in a residential installation. This equipment generates, uses and can radiate radio frequency energy and, if not installed and used in accordance with the instructions, may cause harmful interference to radio communications. However, there is no guarantee that interference will not occur in a particular installation. If this equipment does cause harmful interference to radio or television reception, which can be determined by turning the equipment off and on, the user is encouraged to try to correct the interference by one or more of the following measures:

- Reorient or relocate the receiving antenna.
- Increase the separation between the equipment and receiver.
- Connect the equipment into an outlet on a circuit different from that to which the receiver is connected.
- Consult the dealer or an experienced radio/TV technician for help.

### Contact

Responsible Company: Audio-Technica U.S., Inc.

Address: 1221 Commerce Drive, Stow, Ohio 44224, USA

Tel: 330-686-2600

## For customers in Canada

### ISED statement

CAN ICES-3(B)/NMB-3(B)

# Installation precautions

- This product should be installed by a professional contractor. When determining the installation location and method, be sure to consider the applicable laws and ordinances for the area where the product is being installed.
- Audio-Technica assumes no responsibility in the event of accidents such as the product dropping due to insufficient strength of the installation site or improper installation.
- When working in an elevated location, be sure to choose a stable location with no loose items on the ground before working.
- Install the product in a location where there is no risk of the product being hit or damaged by the movements of nearby people or equipment.
- Be sure to verify the strength of the installation location. The installation location should generally be able to handle at least 10 times the weight of the product.
- Depending on the structure of the ceiling, vibrations may cause noise to be generated. Appropriate separate damping measures are recommended.
- Be sure to use only the included accessories for installation.
- Do not use the included accessories for any purpose other than for use with this product.
- Do not install the product in areas with exposure to high levels of oil or smoke, or where solvents or solutions are volatilized. Such conditions may result in chemical reactions that lead to deterioration or damage of the product's plastic parts, which may cause an accident such as the product dropping from the ceiling.
- Do not install the product in areas where damage from salt or corrosive gas may occur. Such damage may reduce the strength of the product and cause an accident such as the product dropping from the ceiling.
- Be sure to tighten the screws properly and completely. Failing to do so may result in injury due to an accident such as the product dropping from the ceiling.
- Do not pinch the cables during installation.
- Securely attach the seismic cable, zip tie, and safety belt in the specified location.
- Attach the seismic cable so that there is as little slack as possible.
- If the impact from a fall is applied to the seismic cable, replace the cable with a new one.



# Maintenance

When dirty or dusty, wipe clean using a dry, soft cloth.



- Do not use benzine, paint thinners, or electrical contact cleaners. Doing so may cause deformation or malfunction.

# Package contents

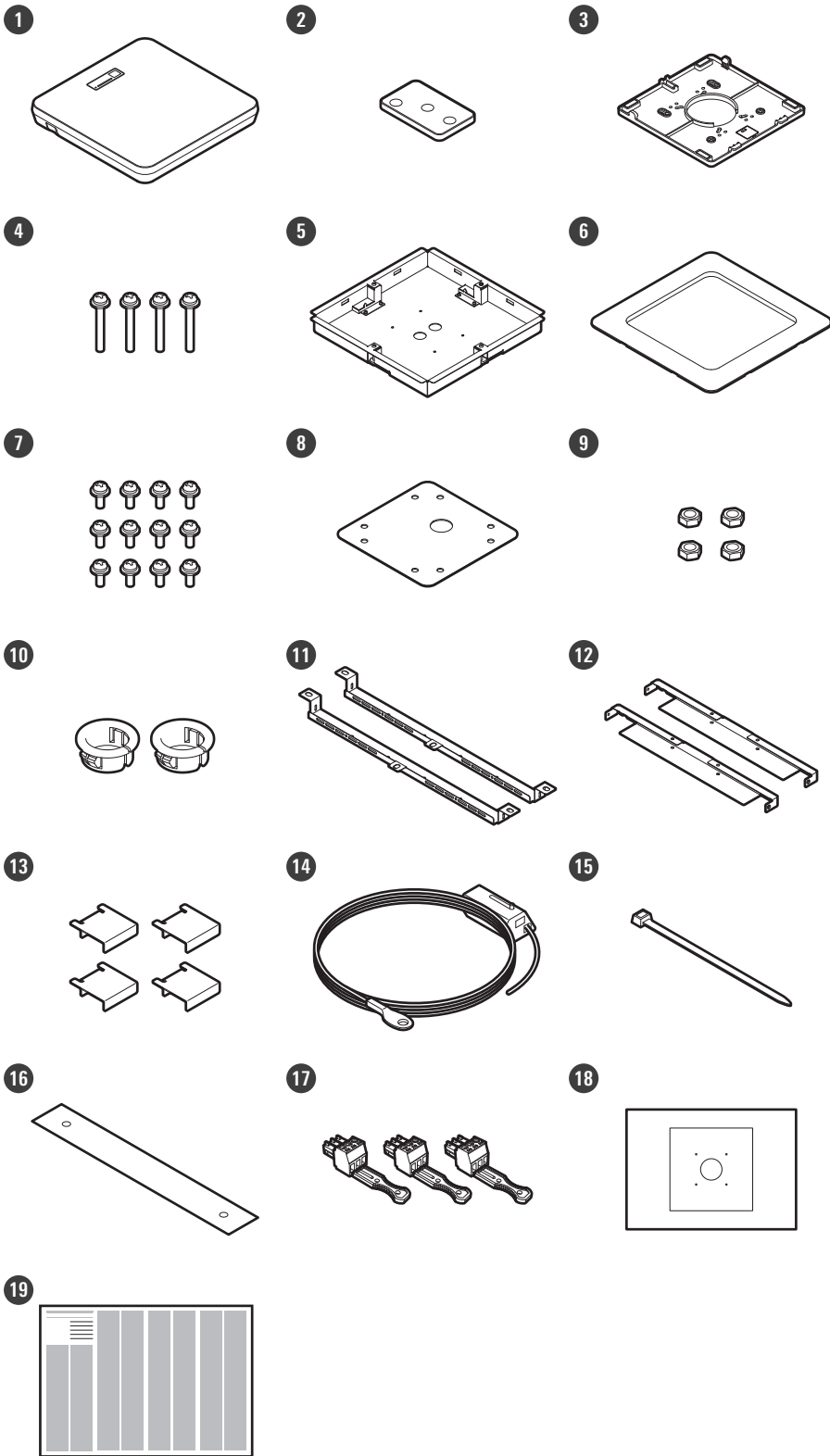

1 Microphone

2 IR remote controller

Includes a lithium coin battery.

## Package contents

- 3 Surface mount adapter
- 4 Screw (M4 × 50 mm) × 4
- 5 Flush mount adapter
- 6 Flush mount cover
- 7 Screw (M4 × 10 mm) × 12
- 8 Hole cover
- 9 Nut × 4
- 10 Snap bushing × 2
- 11 Tile bridge A × 2
- 12 Tile bridge B × 2
- 13 Tile bridge C × 4
- 14 Seismic cable
- 15 Zip tie
- 16 Safety belt
- 17 Euroblock connector × 3
- 18 Installation template
- 19 Quick Start Guide

# Part names and functions

## Microphone

ATND1061LK

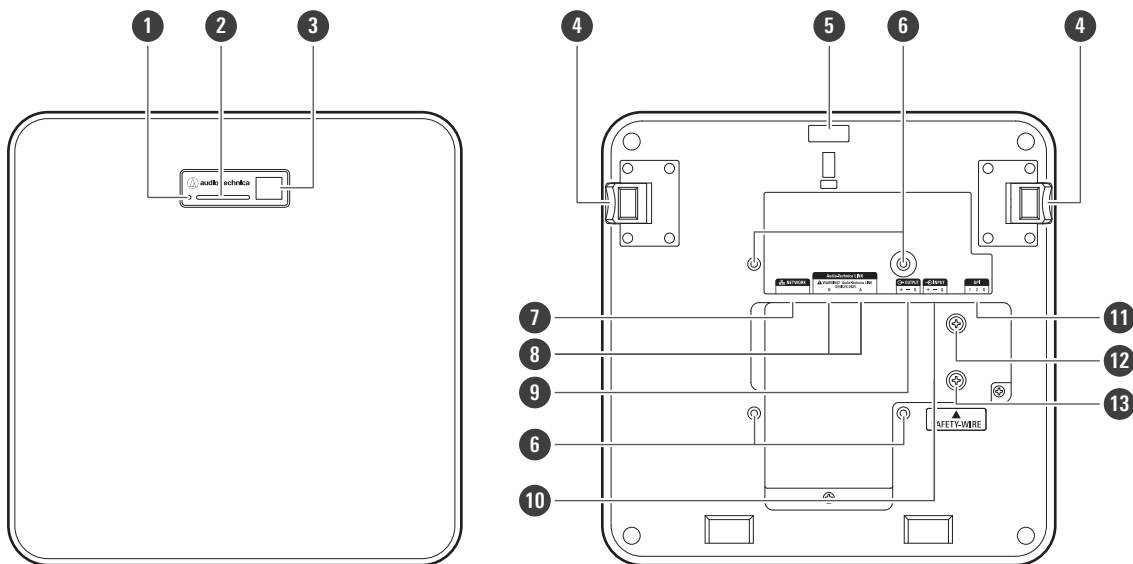

**1 Reset button**

Insert the tip of a pin or other thin device and press this button to reset the microphone.

**2 Indicator lamp**

**3 IR receiver**

**4 Release button**

**5 Hole for zip tie**

**6 Screw holes for VESA mount**

Used when installing with a VESA mount.

**7 Network port**

Used to connect the LAN cable (CAT5e or higher). Connect to the local area network and perform external control using the application.

**8 Audio-Technica LINK A/B ports**

Used for Audio-Technica LINK. Used for connecting the LAN cable (CAT5e or higher). (Make sure to use conductor with a diameter of 24AWG or larger and a shield.)

**9 Analog output port**

Used to connect the balanced cable.

+: Hot

-: Cold

G: Ground

## Part names and functions

### 10 Analog input port

Used to connect the balanced cable.

+: Hot

–: Cold

G: Ground

### 11 GPI port

For details, see "GPI port" (p. 52).

1: GPI1

2: GPI2

G: Ground

### 12 Screw for grounding

Perform grounding as necessary.

### 13 Screw for seismic cable

## ATND1061DAN

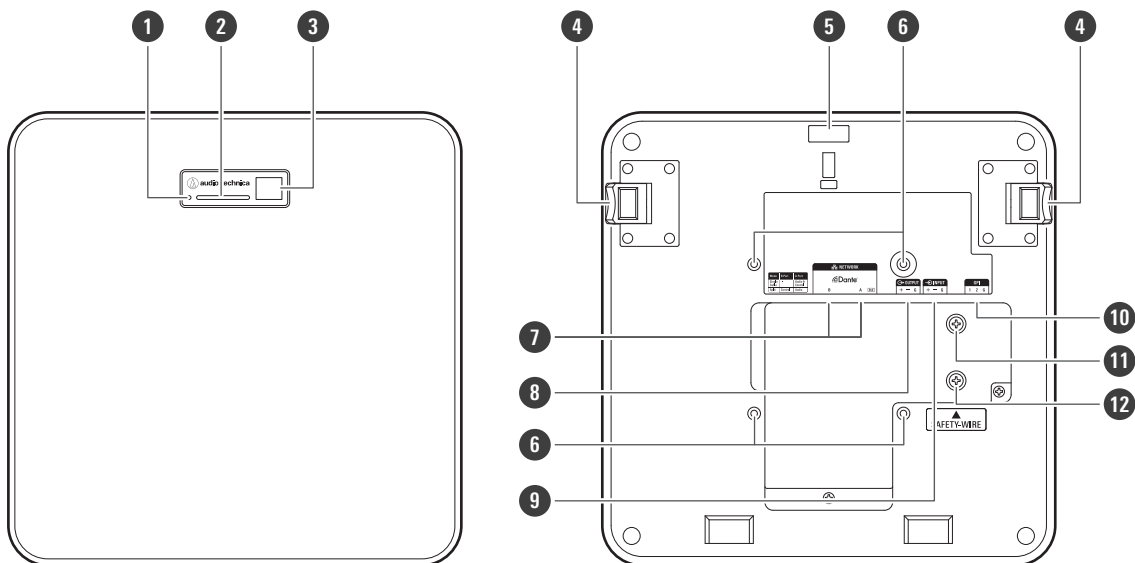

### 1 Reset button

Insert the tip of a pin or other thin device and press this button to reset the microphone.

### 2 Indicator lamp

### 3 IR receiver

### 4 Release button

### 5 Hole for zip tie

### 6 Screw holes for VESA mount

Used when installing with a VESA mount.

## Part names and functions

### 7 Network A/B ports

Dante network ports. Used for connecting the LAN cable (CAT5e or higher). (Make sure to use conductor with a diameter of 24AWG or larger and a shield.) Connect to the local area network and perform external control using the application.

The power supply turns on when the network A port is connected to a PoE switching hub.

### 8 Analog output port

Used to connect the balanced cable.

+: Hot

-: Cold

G: Ground

### 9 Analog input port

Used to connect the balanced cable.

+: Hot

-: Cold

G: Ground

### 10 GPI port

For details, see "GPI port" (p. 52).

1: GPI1

2: GPI2

G: Ground

### 11 Screw for grounding

Perform grounding as necessary.

### 12 Screw for seismic cable

## Indicator lamp

The colors of the indicator lamp can be used to confirm the microphone status.

Indicator lamp	Status
Lights in green <sup>[1]</sup>	Normal (unmuted)
Lights in red <sup>[1]</sup>	Muted
Lights in cyan <sup>[1]</sup>	Power Save Mode
Flashes in red (1 second intervals)	Connecting to the network
Flashes in red (2 second intervals)	Error

[1] The colors of indicator lamp can be changed in "LED Settings".



- For information on indicator lamp colors when presets change, see "How to change presets" (p. 14).
- For information on indicator lamp colors when checking the network mode, see "Checking the network mode" (p. 53).

### IR remote controller

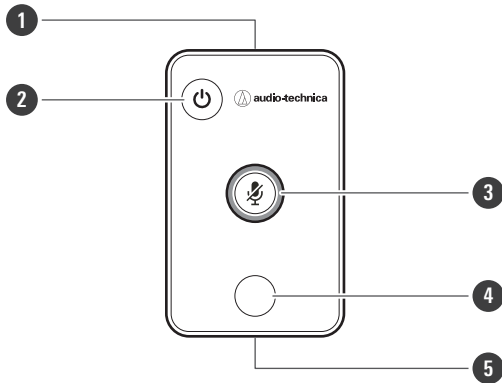

**1 IR transmitter**

**2 Power save mode / cancel button**

Used to turn the power save mode on/off and for canceling preset settings.

During power save mode, only control signals for returning to normal operating mode will be received. Be sure to put the microphone in power save mode when not in use.

**3 Mute/confirm button**

Used to turn All Mute on/off and for finalizing preset settings.

**4 Preset mode button**

Used to change preset settings.

**5 Battery cover**

Includes a lithium coin battery (for confirming initial operation).

Remove the protective film on the battery before use.

Only the specified model (CR2025) of lithium coin battery can be used. When replacing the battery, turn the remote control over and remove the battery cover. Then, insert the battery into the battery cover with the plus (+) side facing upwards.

### How to change presets

Presets can be changed using the IR remote controller.

Settings in presets 1 to 4 will be recalled. For details on presets, see "Presets" (p. 73).

**1 Press the preset mode button.**

» The indicator lamp on the microphone will flash in cyan.

**2 Press and hold the preset mode button (for 3 seconds) before releasing.**

» The indicator lamp on the microphone will flash in red.

### **3 Press the preset mode button to select a preset.**

- The selected preset will change each time the preset mode button is pressed.
- The color of the microphone's indicator lamp will change and flash depending on the number of the selected preset.  
Preset 1: Red  
Preset 2: Green  
Preset 3: Blue  
Preset 4: Yellow
- Changes can be canceled by either pressing the power save mode / cancel button or not pressing any other buttons for a few seconds.

### **4 Finalize the preset selection by pressing the mute/confirm button.**



# Installation

## Hard ceiling installation

### Surface mounting

#### Completed installation

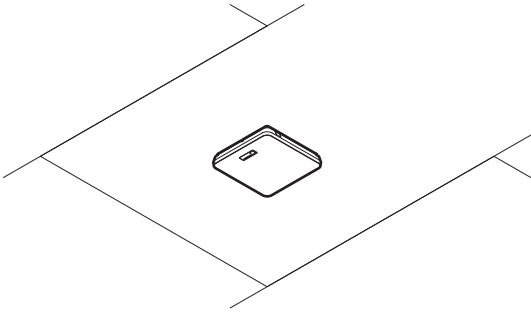

#### Parts required for installation

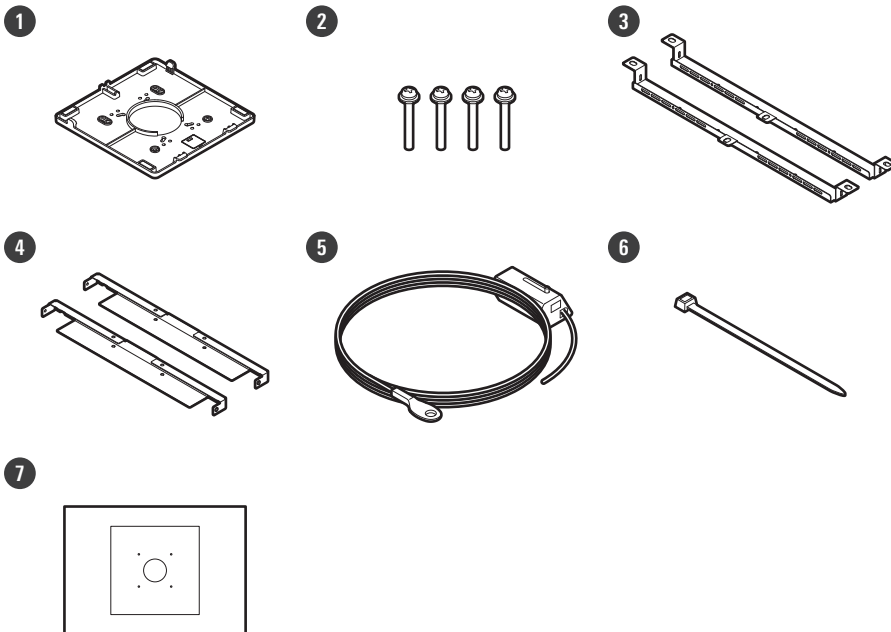

- 1 Surface mount adapter
- 2 Screw (M4 × 50 mm) × 4
- 3 Tile bridge A × 2
- 4 Tile bridge B × 2
- 5 Seismic cable
- 6 Zip tie
- 7 Installation template

# Installation

## 1 Drill holes in the ceiling for attaching the microphone.

- Use the enclosed installation template to drill mounting holes according to the specified dimensions.
- Installation may not be possible in some areas depending on the placement of the ceiling frame. Check the internal structure of the ceiling before choosing an installation location.

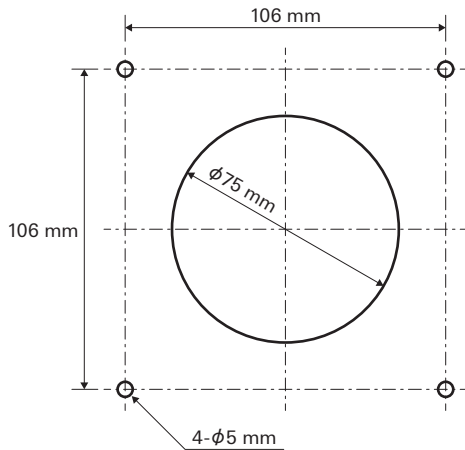

## 2 Attach tile bridges A and tile bridges B to the inside of the ceiling.

- Align the screw holes of tile bridges A and B with the holes drilled into the ceiling to attach.
- Securely attach tile bridges A and B to the ceiling frame so that a sufficient load can be supported.
- If the placement of the ceiling frame makes it difficult to ensure a secure installation, use nuts and bolts to attach tile bridges A securely to the ceiling frame mounting holes.  
Applicable bolt size for mounting holes of tile bridges A: W3/8 or M10

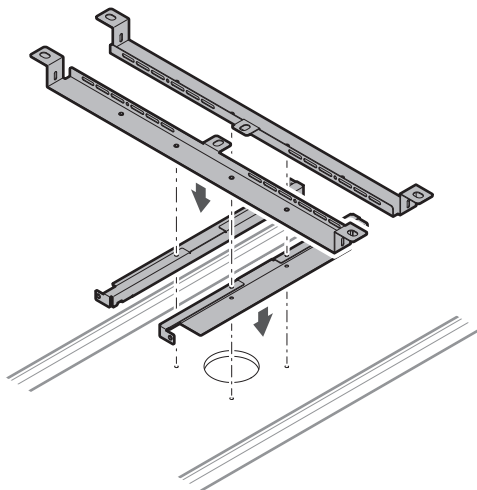

## 3 Attach the surface mount adapter using the screws (M4 x 50 mm).

- The stamping on the surface mount adapter indicates the orientation of the microphone.

# Installation

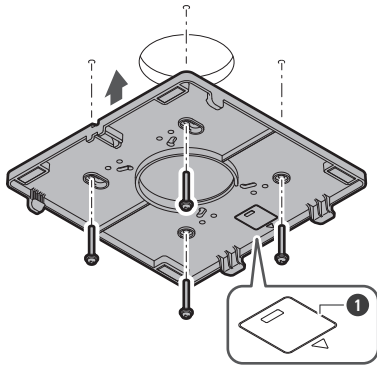

1 Stamping indicating microphone orientation

## 4 Run the cables inside the ceiling.

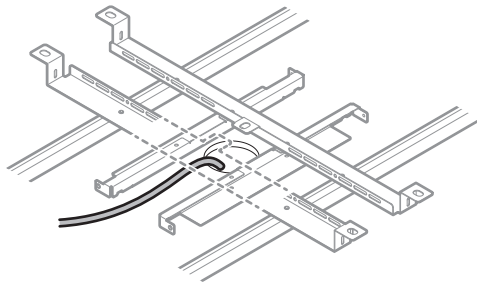

## 5 Attach the seismic cable to the ceiling frame.

- Securely attach the seismic cable to a strong point on the ceiling frame.
- Slide the unlock pins to release the lock for adjusting the wire.

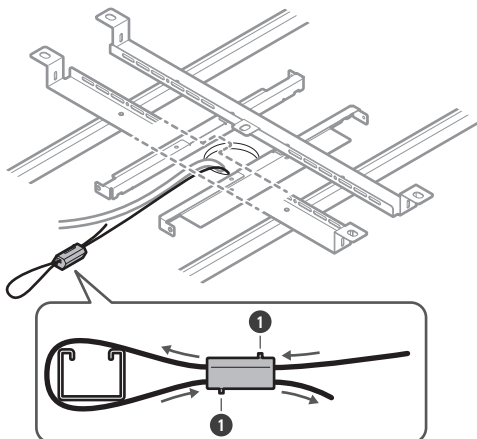

1 Unlock pins

# Installation



- Attach the seismic cable so that there is as little slack as possible.
- Using the seismic cable with a large amount of slack could increase the impact exerted were the microphone to be dropped and may result in an accident, injury, or damage to the microphone.
- If the impact from a fall is applied to the seismic cable, replace the cable with a new one.

## 6 Pass the cables and the seismic cable through the hole in the surface mount adapter.

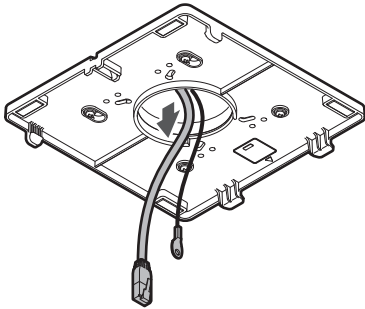

## 7 Attach the seismic cable to the microphone using the screw for seismic cable.

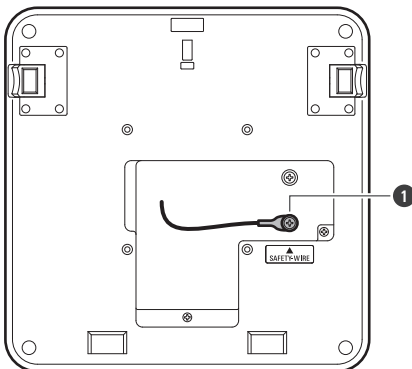

- 1 Screw for seismic cable

## 8 Connect the wired cables to the microphone.

- See "Connection procedure" (p. 45) for details on connecting the cables.

## 9 Pass the zip tie through the microphone and the surface mount adapter to attach the microphone to the surface mount adapter.

- Make sure the tab on the surface mount adapter is securely hooked on the microphone before pushing up the other side of the microphone to attach it.

# Installation

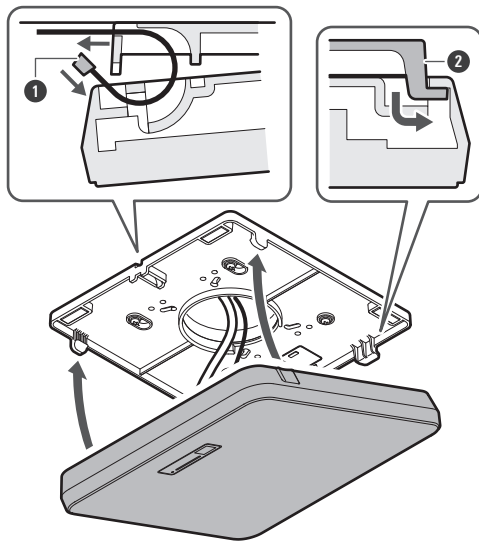

- 1 Zip tie
- 2 Tab on surface mount adapter

## 10 Tighten the zip tie to secure.

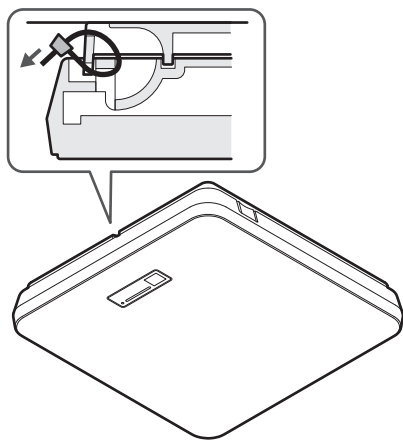

# Installation

## Flush mounting

### Completed installation

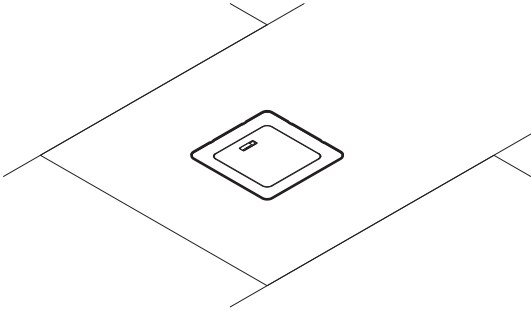

### Parts required for installation

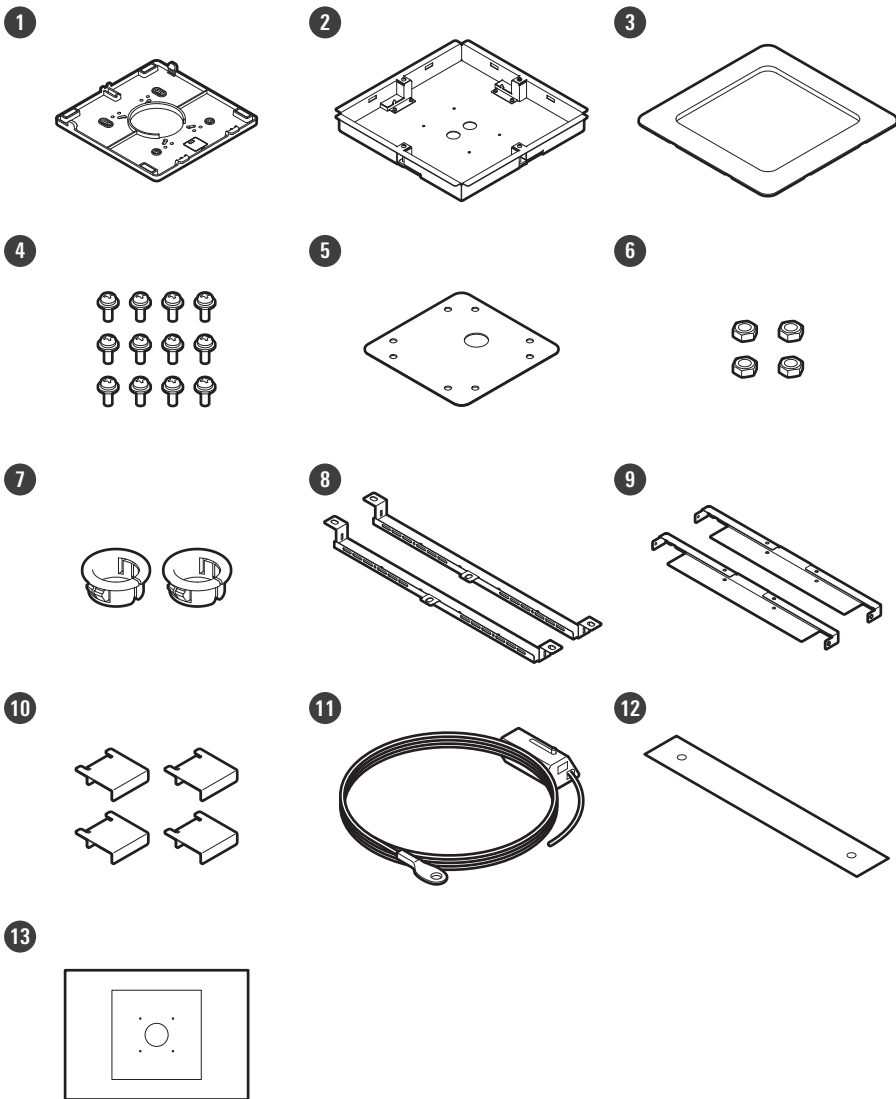

1 Surface mount adapter

# Installation

- ② Flush mount adapter
- ③ Flush mount cover
- ④ Screw (M4 × 10 mm) × 12
- ⑤ Hole cover
- ⑥ Nut × 4
- ⑦ Snap bushing × 2
- ⑧ Tile bridge A × 2
- ⑨ Tile bridge B × 2
- ⑩ Tile bridge C × 4
- ⑪ Seismic cable
- ⑫ Safety belt
- ⑬ Installation template

## 1 Cut out a square hole in the ceiling for attaching the microphone.

- Use the enclosed installation template to cut out a mounting hole according to the specified dimensions.
- Installation may not be possible in some areas depending on the placement of the ceiling frame. Check the internal structure of the ceiling before choosing an installation location.
- Max. ceiling thickness for installation: 25 mm

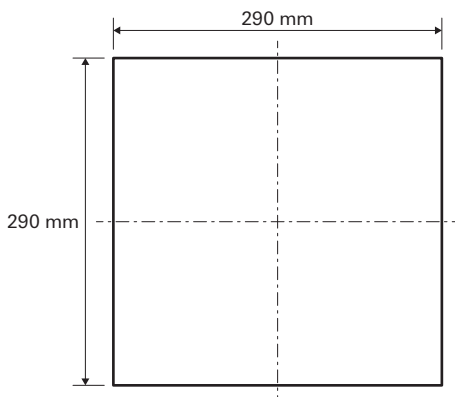

## 2 Attach tile bridges A and tile bridges B to the inside of the ceiling using the screws (M4 × 10 mm). Adjust tile bridges C to the height of the ceiling frame and attach using the screws (M4 × 10 mm).

- Attach tile bridges A and B to the ceiling by aligning with the square hole cut into the ceiling.
- Securely attach tile bridges A, B, and C to the ceiling frame so that a sufficient load can be supported.
- If the placement of the ceiling frame makes it difficult to ensure a secure installation, use nuts and bolts to attach tile bridges A securely to the ceiling frame mounting holes.  
Applicable bolt size for mounting holes of tile bridges A: W3/8 or M10

## Installation

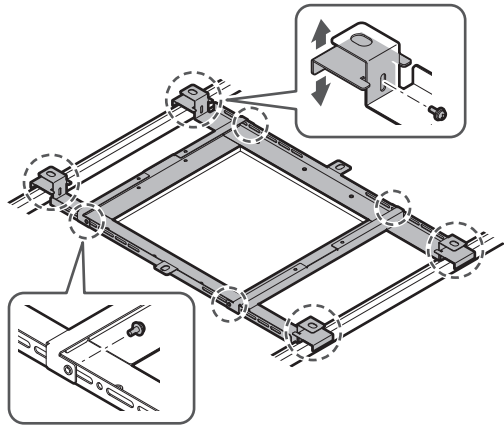

### 3 Attach the surface mount adapter to the flush mount adapter using the screws (M4 × 10 mm).

- Align the arrows on both the flush mount adapter and the stamping on surface mount adapter when attaching.

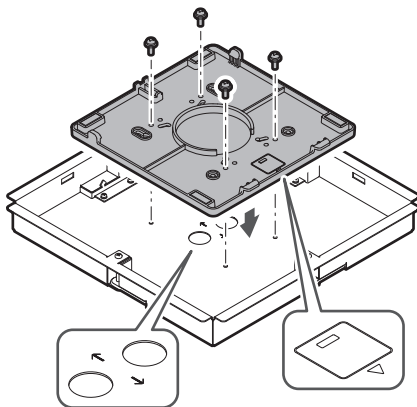

### 4 Attach the hole cover with the nuts.

- If using both holes, skip this step and proceed to the next step.

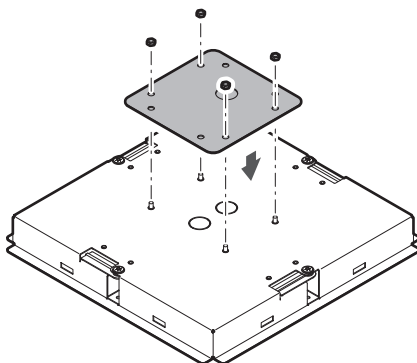



## Installation

### 5 Attach the snap bushings.

- Press your hand on the snap bushing from above to insert it into the wiring hole.
- When wiring a large number of cables, attach both snap bushings without using the hole cover.

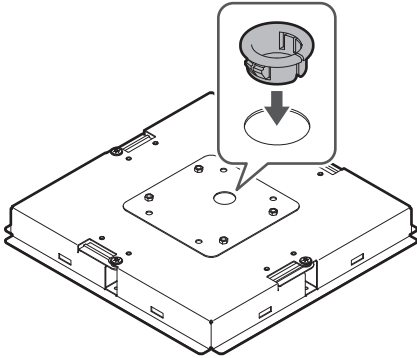

### 6 Run the cables inside the ceiling.

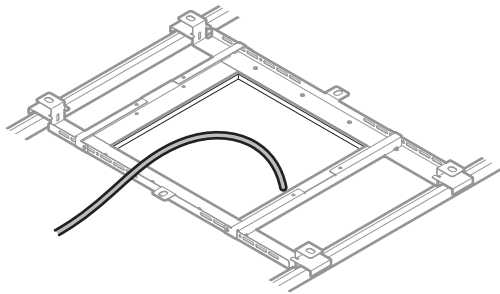

### 7 Attach the seismic cable to the ceiling frame.

- Securely attach the seismic cable to a strong point on the ceiling frame.
- Slide the unlock pins to release the lock for adjusting the wire.

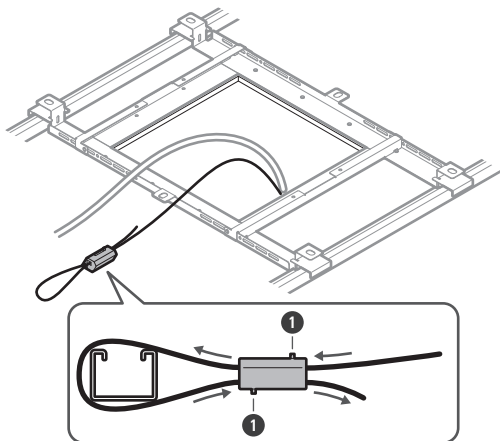

# Installation

## 1 Unlock pins



- Attach the seismic cable so that there is as little slack as possible.
- Using the seismic cable with a large amount of slack could increase the impact exerted were the microphone to be dropped and may result in an accident, injury, or damage to the microphone.
- If the impact from a fall is applied to the seismic cable, replace the cable with a new one.

## 8 Pass the cable and the seismic cable through the snap bushing hole in the flush mount adapter, insert the flush mount adapter into the square hole cut into the ceiling, and secure with screws to attach the flush mount adapter.

- The stamping on the surface mount adapter indicates the orientation of the microphone.
- Securely tighten the mounting screws when attaching the flush mount adapter.

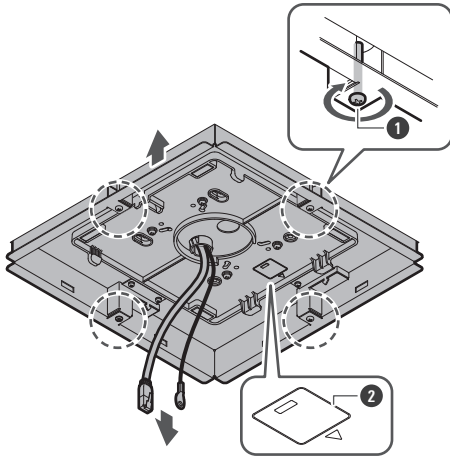

### 1 Mounting screws

### 2 Stamping indicating microphone orientation

## 9 Attach the seismic cable to the microphone using the screw for seismic cable.

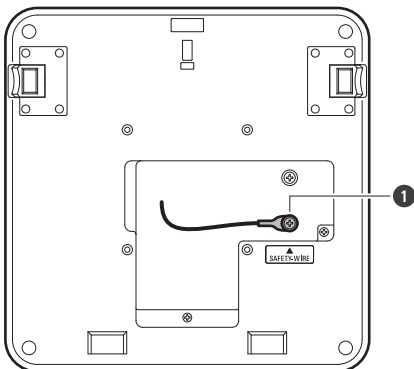

### 1 Screw for seismic cable

## Installation

### 10 Connect the wired cables to the microphone.

- See "Connection procedure" (p. 45) for details on connecting the cables.

### 11 Attach the microphone to the surface mount adapter.

- Make sure the tab on the surface mount adapter is securely hooked on the microphone before pushing up the other side of the microphone to attach it.

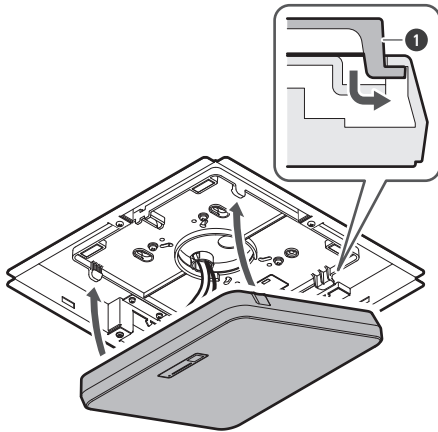

1 Tab on surface mount adapter

### 12 Attach the safety belt by hooking it onto the flush mount adapter and flush mount cover.

- Ensure the safety belt is attached in the correct orientation.

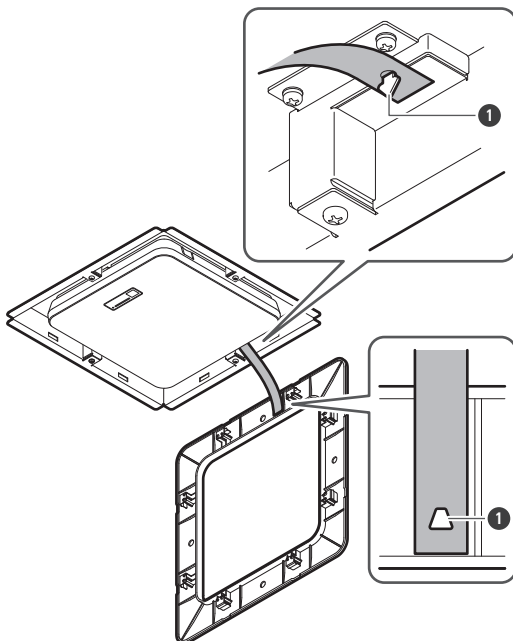

1 Hooks for safety belt attachment

## Installation

### 13 Attach the flush mount cover by inserting it into the flush mount adapter.

- Avoid bending or twisting the safety belt when attaching the flush mount cover.

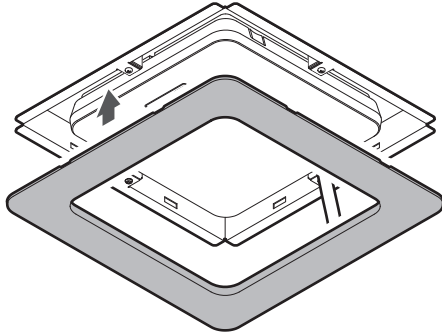

## Grid ceiling installation

### Surface mounting

#### Completed installation

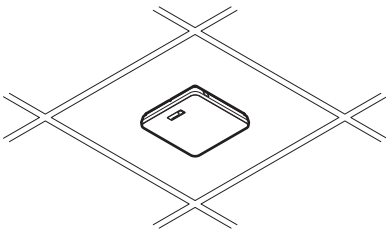

# Installation

## Parts required for installation

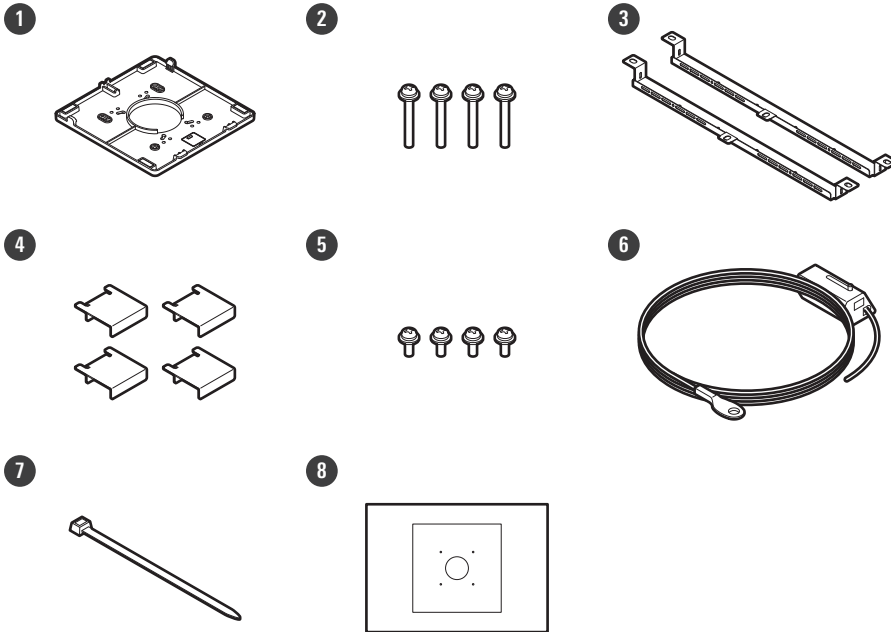

- 1 Surface mount adapter
- 2 Screw (M4 x 50 mm) x 4
- 3 Tile bridge A x 2
- 4 Tile bridge C x 4
- 5 Screw (M4 x 10 mm) x 4
- 6 Seismic cable
- 7 Zip tie
- 8 Installation template

**1** Remove the ceiling tile where the microphone will be installed.

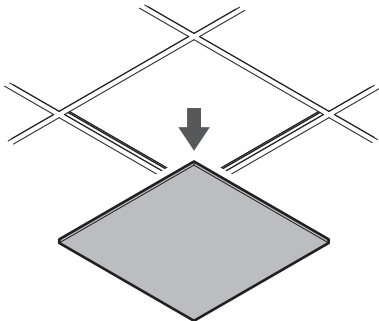

**2** Drill holes in the ceiling tile for attaching the microphone.

- Use the enclosed installation template to drill mounting holes according to the specified dimensions.
- Align the mounting holes with the center of the ceiling tile.

## Installation

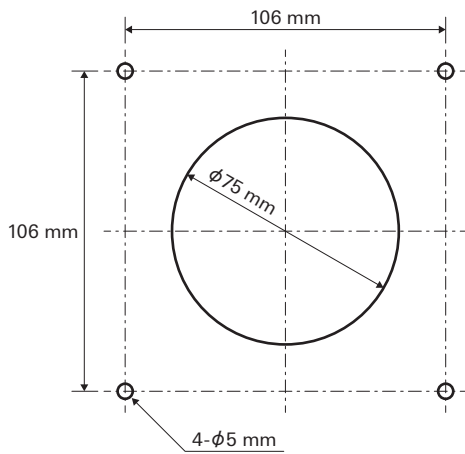

- 3** Attach tile bridges A behind the ceiling tile.  
Attach tile bridges C loosely to tile bridges A using the screws (M4 × 10 mm).

- Align the screw holes of tile bridges A with the holes drilled into the ceiling tile to attach.

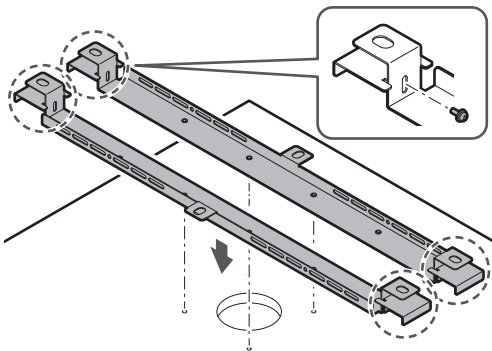

- 4** Attach the surface mount adapter using the screws (M4 × 50 mm).

- The stamping on the surface mount adapter indicates the orientation of the microphone.

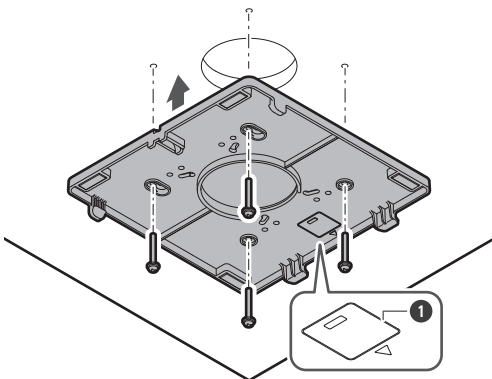

## Installation

- 1 Stamping indicating microphone orientation

### 5 Run the cables inside the ceiling.

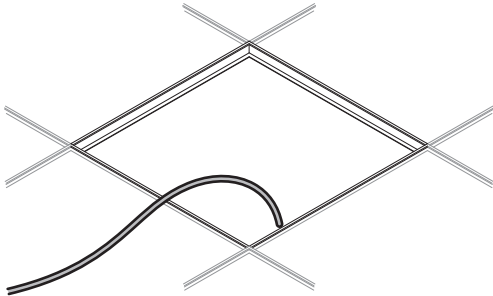

### 6 Attach the seismic cable to the ceiling frame.

- Securely attach the seismic cable to a strong point on the ceiling frame.
- Slide the unlock pins to release the lock for adjusting the wire.

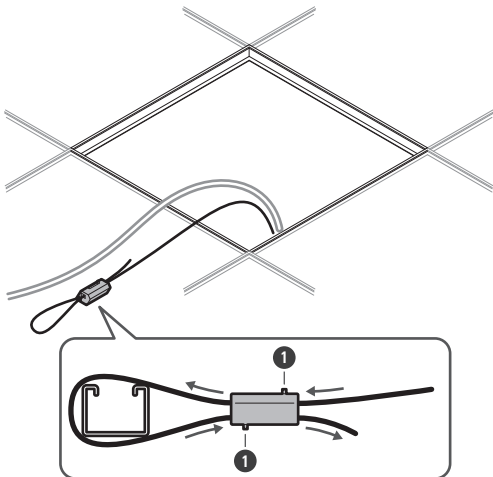

- 1 Unlock pins



- Attach the seismic cable so that there is as little slack as possible.
- Using the seismic cable with a large amount of slack could increase the impact exerted were the microphone to be dropped and may result in an accident, injury, or damage to the microphone.
- If the impact from a fall is applied to the seismic cable, replace the cable with a new one.

### 7 Pass the cables and the seismic cable through the hole in the surface mount adapter and return the ceiling tile to its original location.

## Installation

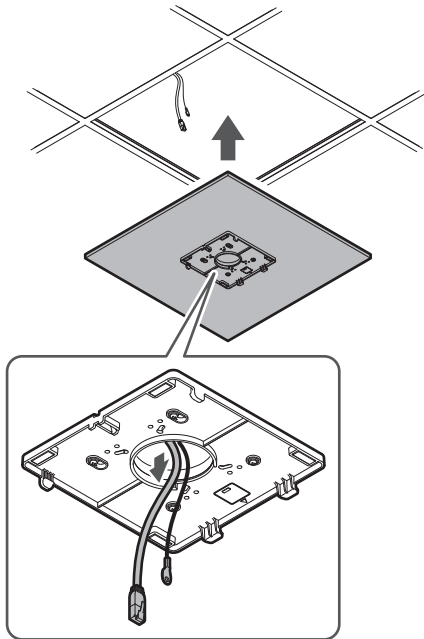

### 8 Adjust the tile bridge C assembly to the height of the ceiling frame and tighten the screws (M4 x 10 mm) to attach.

- Securely attach tile bridges A and C to the ceiling frame so that a sufficient load can be supported.
- If the placement of the ceiling frame makes it difficult to ensure a secure installation, use nuts and bolts to attach tile bridges A securely to the ceiling frame mounting holes.  
Applicable bolt size for mounting holes of tile bridges A: W3/8 or M10

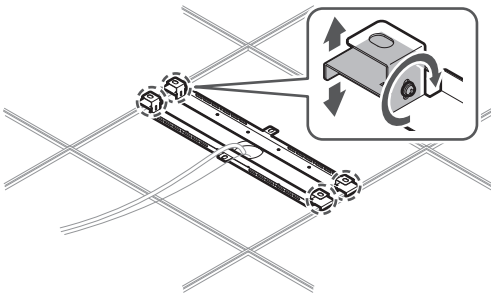

### 9 Attach the seismic cable to the microphone using the screw for seismic cable.



## Installation

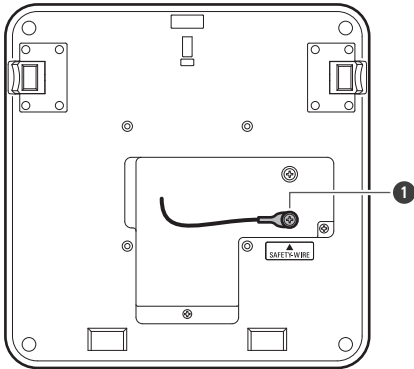

- 1 Screw for seismic cable

### 10 Connect the wired cables to the microphone.

- See "Connection procedure" (p. 45) for details on connecting the cables.

### 11 Pass the zip tie through the microphone and the surface mount adapter to attach the microphone to the surface mount adapter.

- Make sure the tab on the surface mount adapter is securely hooked on the microphone before pushing up the other side of the microphone to attach it.

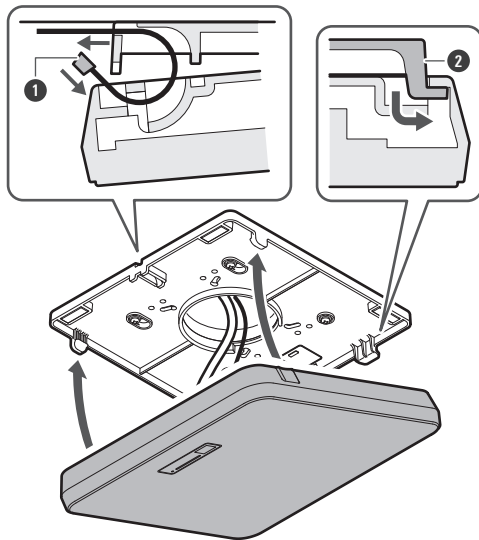

- 1 Zip tie  
2 Tab on surface mount adapter

### 12 Tighten the zip tie to secure.

# Installation

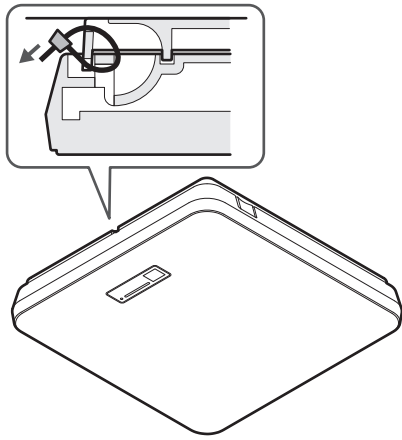

## Flush mounting

### Completed installation

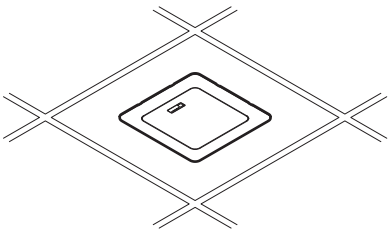

# Installation

## Parts required for installation

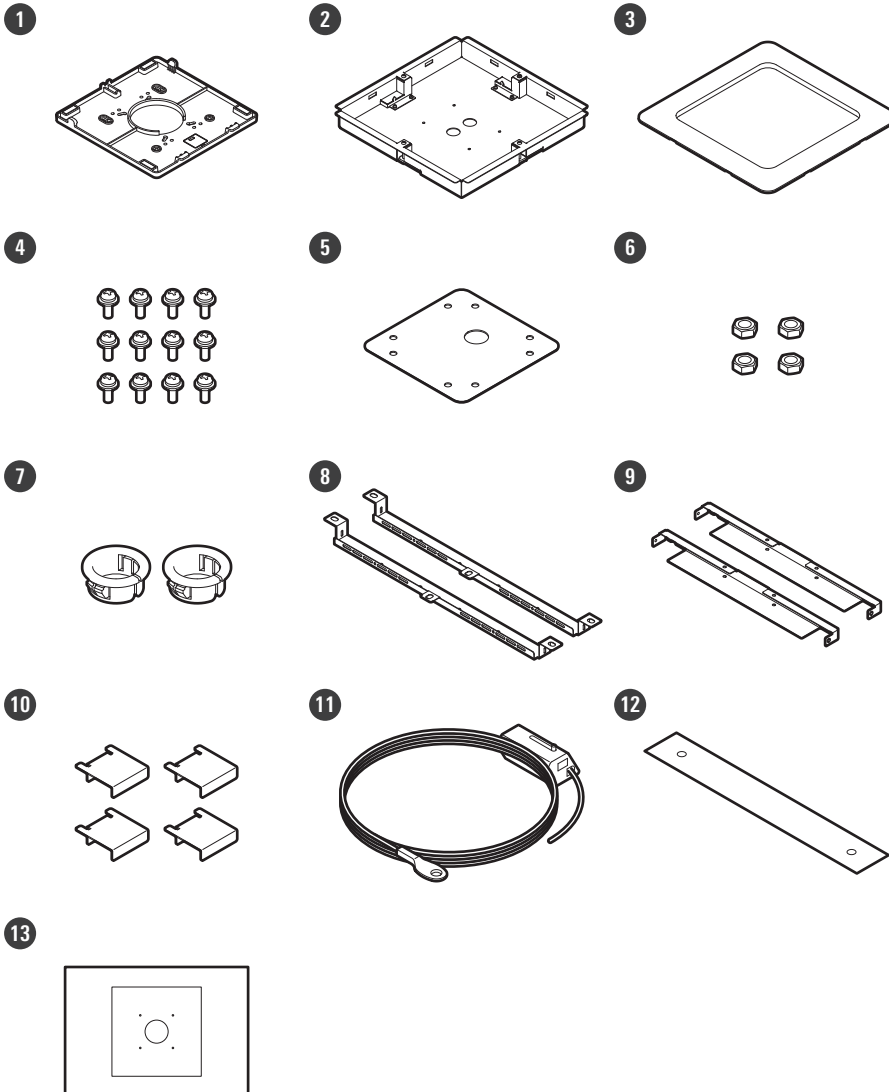

- 1 Surface mount adapter
- 2 Flush mount adapter
- 3 Flush mount cover
- 4 Screw (M4 × 10 mm) × 12
- 5 Hole cover
- 6 Nut × 4
- 7 Snap bushing × 2
- 8 Tile bridge A × 2
- 9 Tile bridge B × 2
- 10 Tile bridge C × 4
- 11 Seismic cable
- 12 Safety belt

# Installation

## 13 Installation template

**1** Remove the ceiling tile where the microphone will be installed.

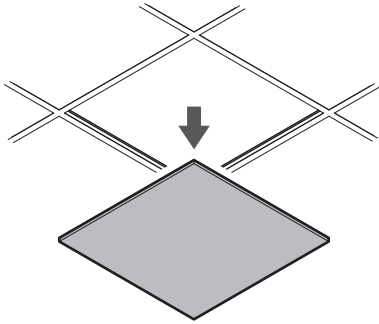

**2** Cut out a square hole in the ceiling for attaching the microphone.

- Use the enclosed installation template to cut out a mounting hole according to the specified dimensions.
- Align the mounting holes with the center of the ceiling tile.
- Max. ceiling tile thickness for installation: 25 mm

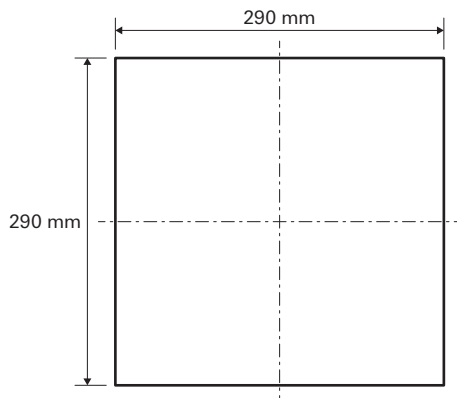

**3** Attach tile bridges A and tile bridges B behind the ceiling tile using the screws (M4 x 10 mm). Attach tile bridges C loosely to tile bridges A using the screws (M4 x 10 mm).

- Attach tile bridges A and B to the ceiling by aligning with the square hole cut into the ceiling tile.

## Installation

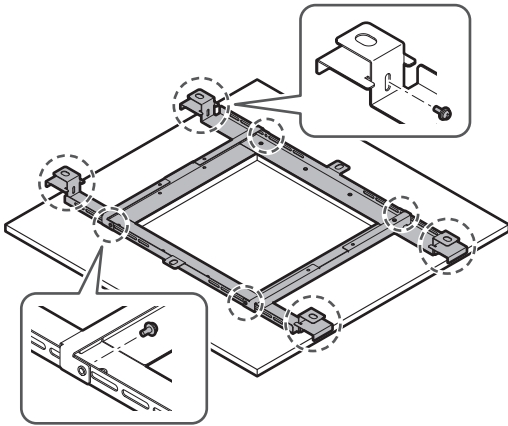

### 4 Attach the surface mount adapter to the flush mount adapter using the screws (M4 × 10 mm).

- Align the arrows on both the flush mount adapter and the stamping on surface mount adapter when attaching.

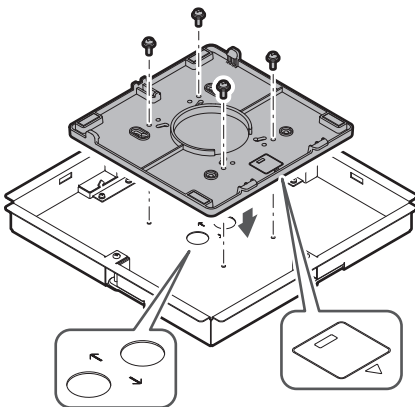

### 5 Attach the hole cover with the nuts.

- If using both holes, skip this step and proceed to the next step.

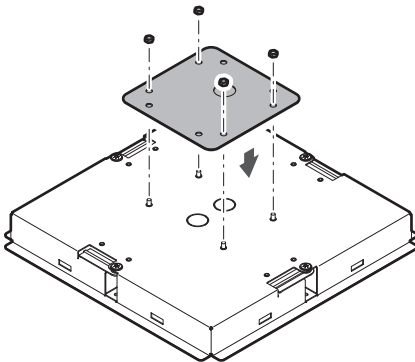

## Installation

### 6 Attach the snap bushings.

- Press your hand on the snap bushing from above to insert it into the wiring hole.
- When wiring a large number of cables, attach both snap bushings without using the hole cover.

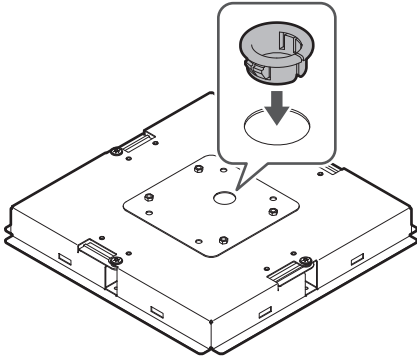

### 7 Insert the flush mount adapter into the square hole cut into the ceiling tile, and secure with screws to attach the flush mount adapter.

- The stamping on the surface mount adapter indicates the orientation of the microphone.
- Securely tighten the mounting screws when attaching the flush mount adapter.

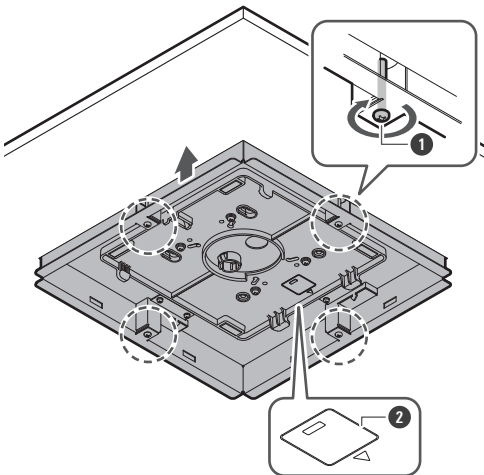

- ❶ Mounting screws
- ❷ Stamping indicating microphone orientation

### 8 Run the cables inside the ceiling.

## Installation

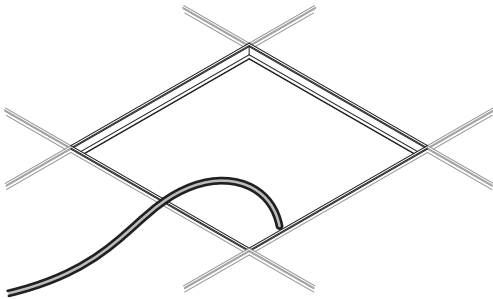

### 9 Attach the seismic cable to the ceiling frame.

- Securely attach the seismic cable to a strong point on the ceiling frame.
- Slide the unlock pins to release the lock for adjusting the wire.

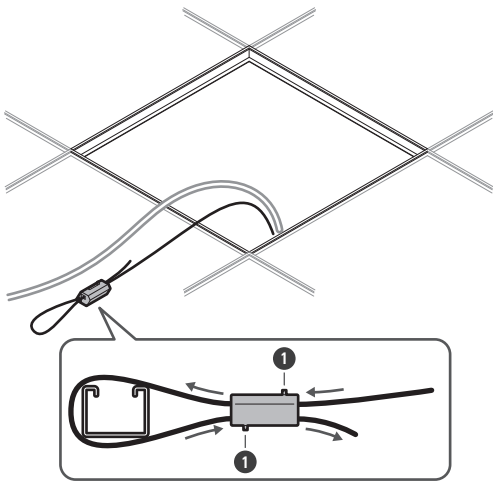

1 Unlock pins



- Attach the seismic cable so that there is as little slack as possible.
- Using the seismic cable with a large amount of slack could increase the impact exerted were the microphone to be dropped and may result in an accident, injury, or damage to the microphone.
- If the impact from a fall is applied to the seismic cable, replace the cable with a new one.

### 10 Pass the cables and the seismic cable through the snap bushing hole in the flush mount adapter and return the ceiling tile to its original location.

## Installation

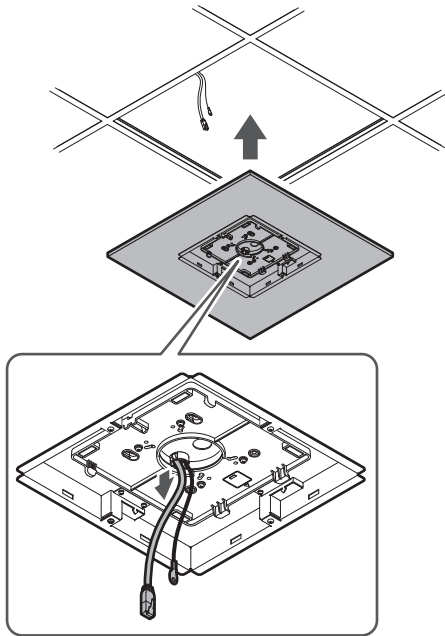

### 11 Adjust the tile bridge C assembly to the height of the ceiling frame and tighten the screws (M4 x 10 mm) to attach.

- Securely attach tile bridges A, B, and C to the ceiling frame so that a sufficient load can be supported.
- If the placement of the ceiling frame makes it difficult to ensure a secure installation, use nuts and bolts to attach tile bridges A securely to the ceiling frame mounting holes.  
Applicable bolt size for mounting holes of tile bridges A: W3/8 or M10

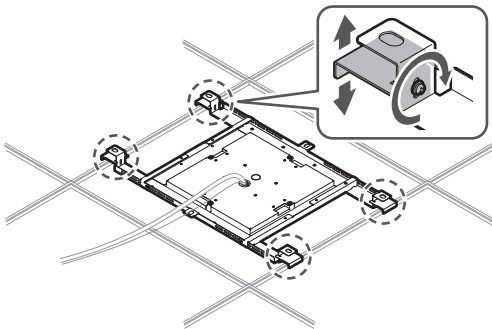

### 12 Attach the seismic cable to the microphone using the screw for seismic cable.



## Installation

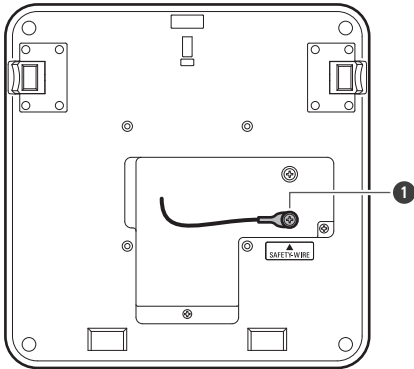

- 1 Screw for seismic cable

### 13 Connect the wired cables to the microphone.

- See "Connection procedure" (p. 45) for details on connecting the cables.

### 14 Attach the microphone to the surface mount adapter.

- Make sure the tab on the surface mount adapter is securely hooked on the microphone before pushing up the other side of the microphone to attach it.

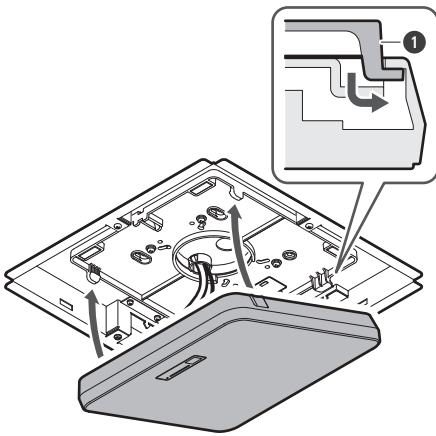

- 1 Tab on surface mount adapter

### 15 Attach the safety belt by hooking it onto the flush mount adapter and flush mount cover.

- Ensure the safety belt is attached in the correct orientation.

## Installation

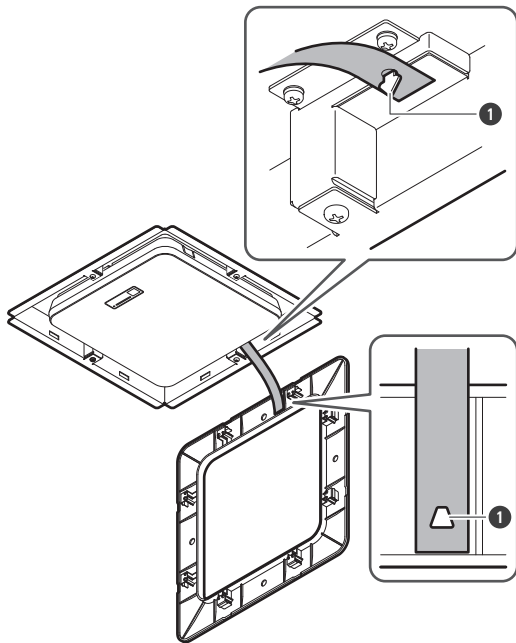

1 Hooks for safety belt attachment

### 16 Attach the flush mount cover by inserting it into the flush mount adapter.

- Avoid bending or twisting the safety belt when attaching the flush mount cover.

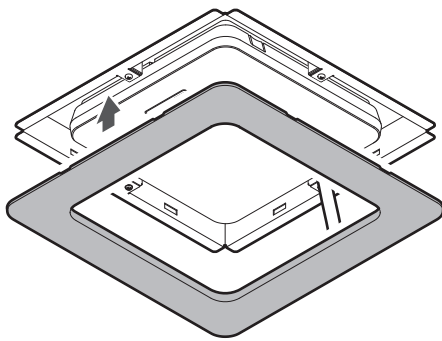

## Installation with VESA mount

Installation is possible using a commercially available VESA mount.

VESA standard dimensions: 75 mm pitch

Mounting screw hole: M4 (8 mm depth)

- Do not use screws with a length that exceeds the sum of the mounting screw hole depth (8 mm) of this product and the thickness of the screw mounting part of the VESA mount. Make sure to check the user manual for the VESA mount.
- Tighten the screws to prevent any looseness.  
Screw tightening torque: 1.2 N·m or less

## Installation

- To prevent the product from falling, secure the seismic cable to the microphone before attaching it to a strong location on the structure of the VESA mount.

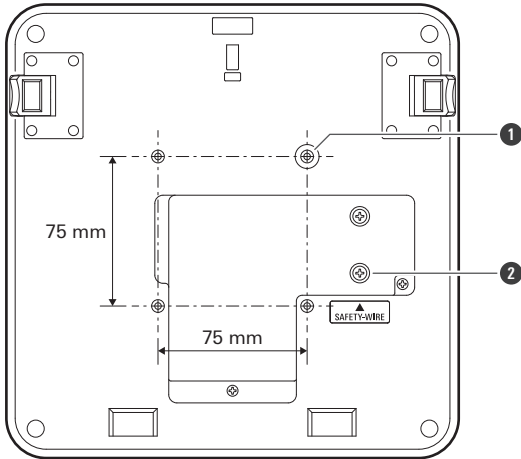

- 1 Screw holes for VESA mount
- 2 Screw for seismic cable

## Removing the microphone

### Surface mounting

- 1 Cut away the zip tie used to secure the microphone to the surface mount adapter.

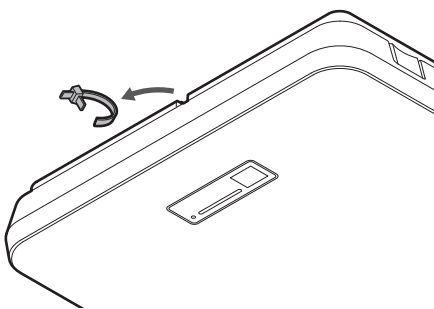

- 2 Remove the microphone from the surface mount adapter while pressing the release button on the microphone.

## Installation

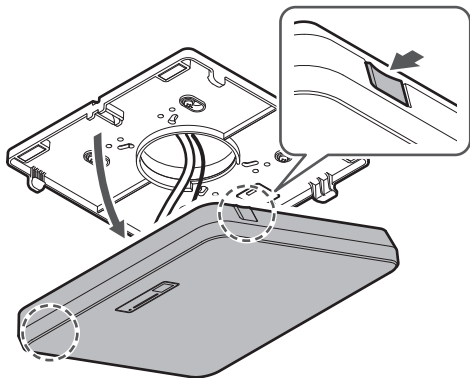

### Flush mounting

**1** Insert a flathead screwdriver between the recesses located on the sides of the flush mount cover (two on each side) and the flush mount adapter. Then lower and remove the flush mount cover.

- The tabs on the flush mount cover hook onto the flush mount adapter. Insert a flathead screwdriver as far into the recess of the flush mount cover as possible and lower the flush mount cover downward while pushing in the tab.
- Removal can be facilitated by disengaging one tab before lowering the flush mount cover.
- Remove the safety belt together with the flush mount cover.

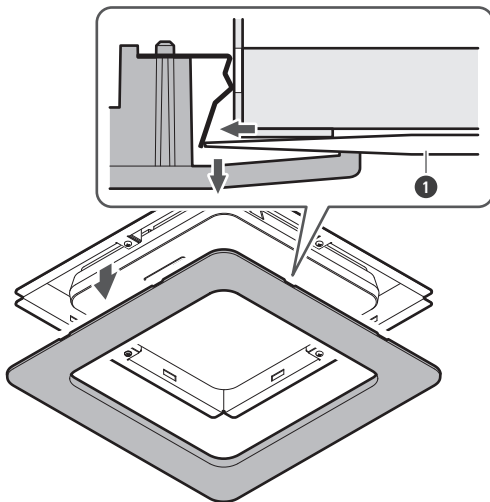

**1** Flathead screwdriver

**2** Remove the microphone from the surface mount adapter while pressing the release button on the microphone.

# Installation

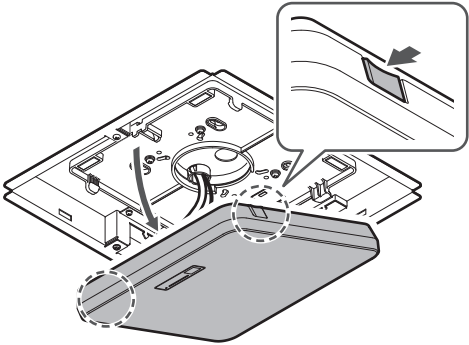

# Connection procedure

## System connection examples

### ATND1061LK (connecting only one unit)

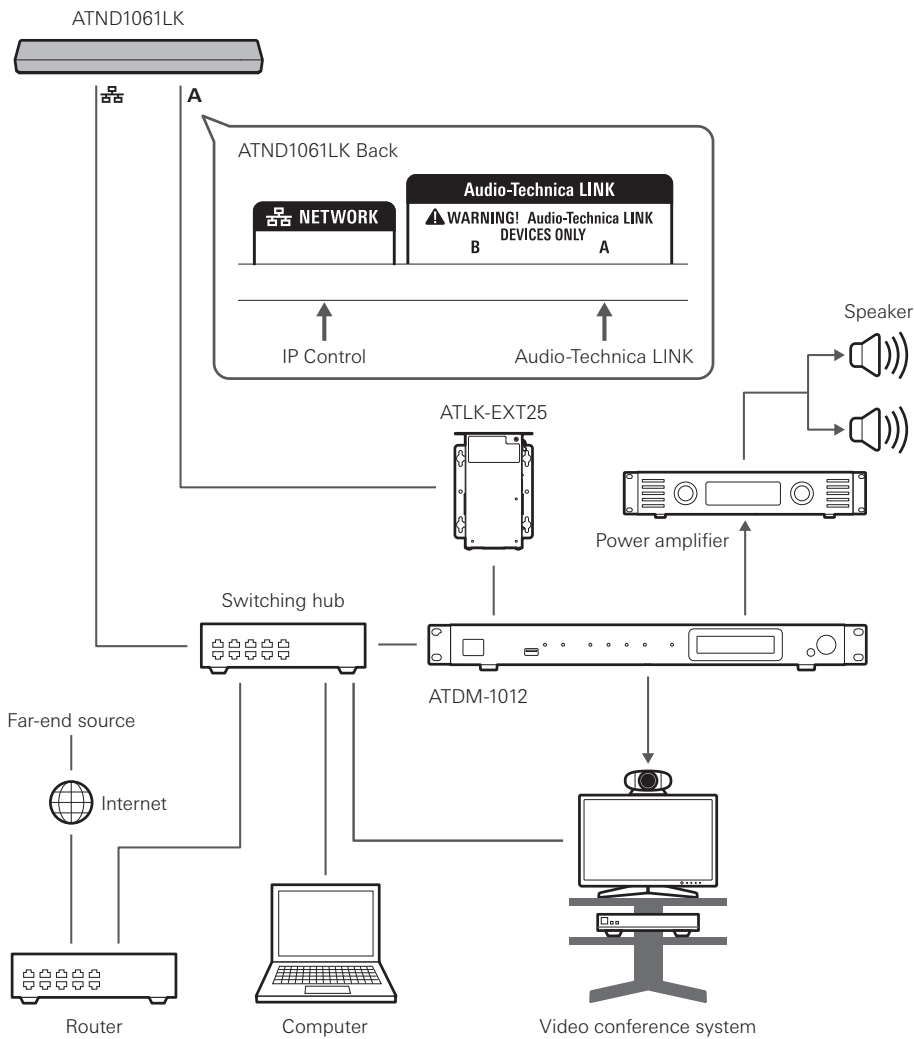

- An AC adapter (sold separately) or PoE switching hub is necessary to use ATLK-EXT25.

## Connection procedure

### ATND1061LK (connecting multiple units)

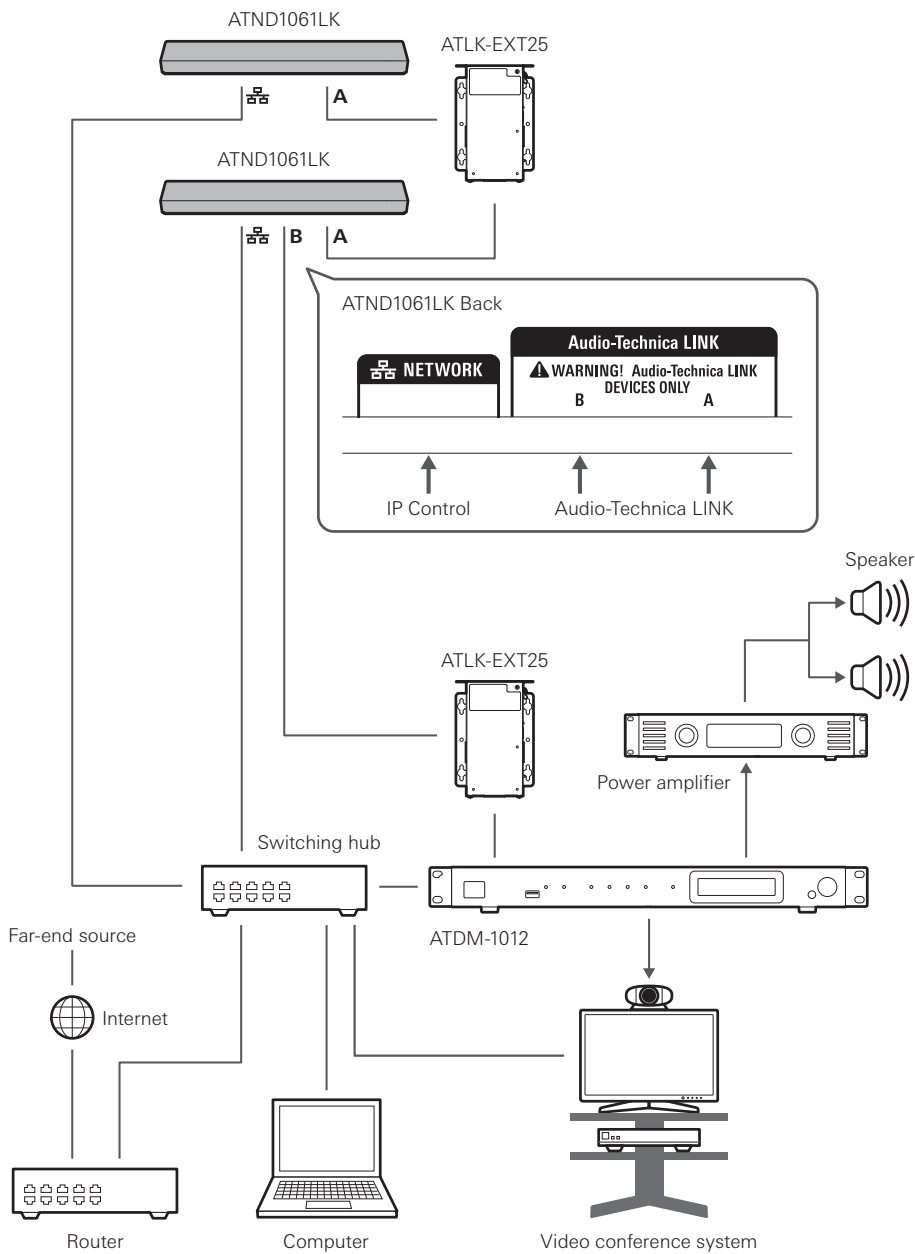

- An AC adapter (sold separately) or PoE switching hub is necessary to use ATLK-EXT25.

# Connection procedure

## ATND1061DAN (single cable mode)

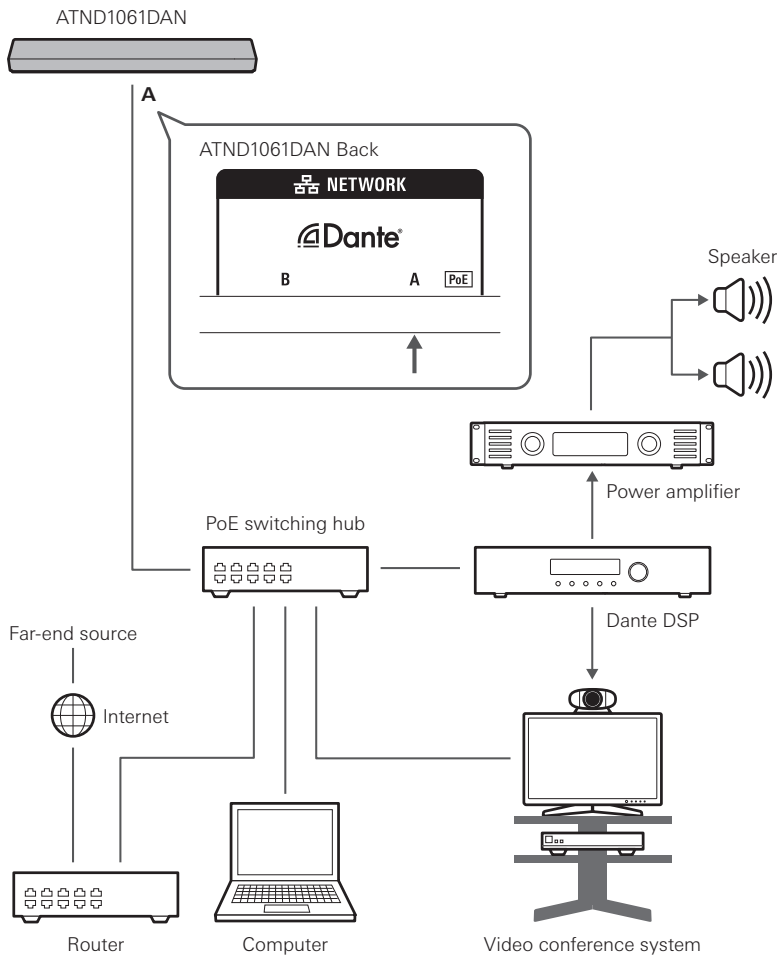



# Connection procedure

## ATND1061DAN (split mode)

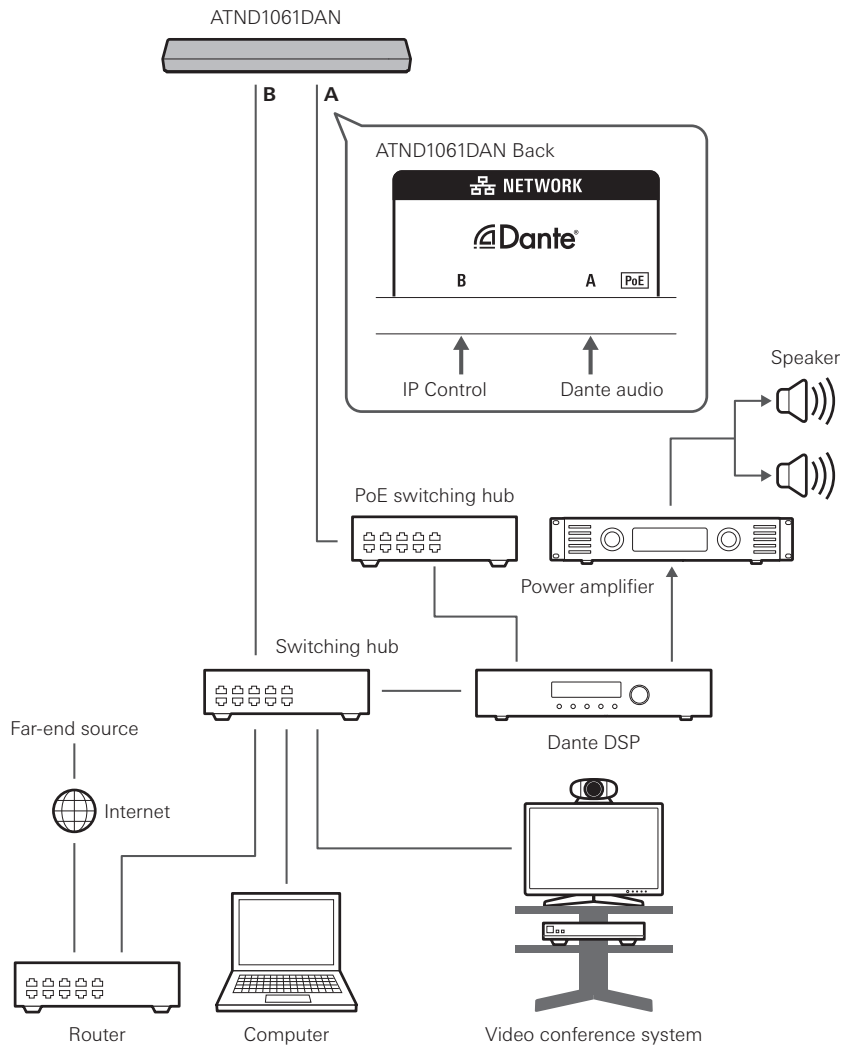

## ATND1061DAN (connecting multiple units)

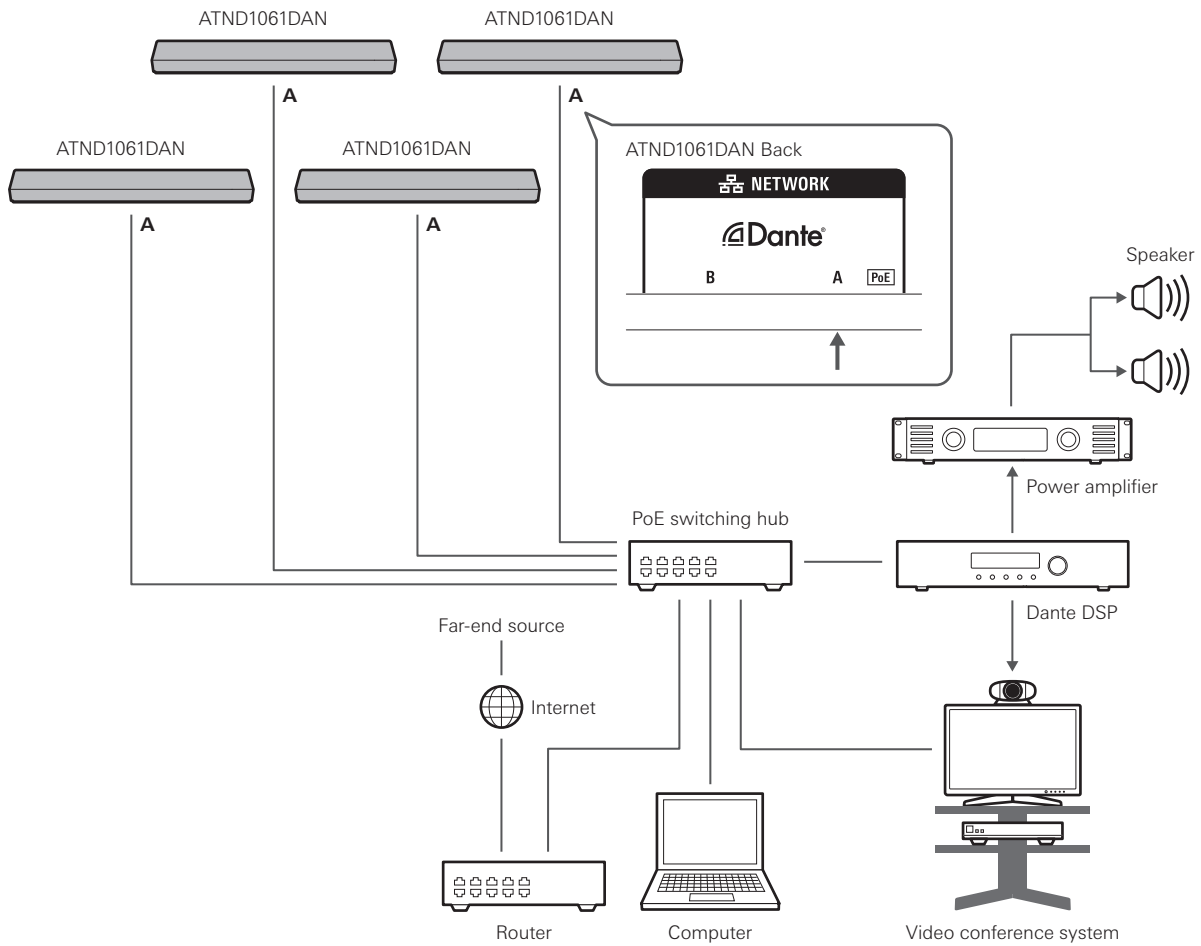

- For details on auto mix settings when connecting multiple units, see the user manual -Digital Microphone Manager Edition-.

## Connection procedure

### ATND1061DAN (single cable mode and analog I/O)

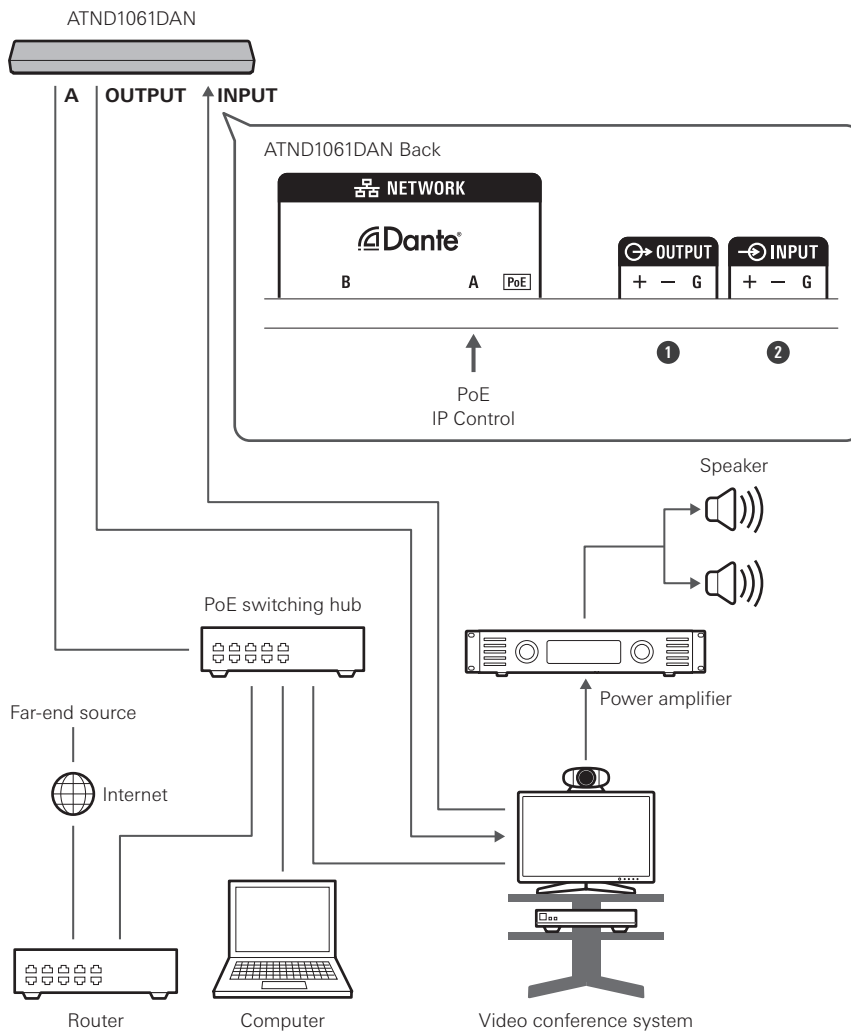

- 1 OUTPUT: Connection to analog input for video conference system (far-end transmission)
- 2 INPUT: Connection to analog output for video conference system (far-end source)

## Connecting Euroblock connectors

### 1 Strip and wire the cable as shown in the diagram.

- Do not solder stranded wires.

## Connection procedure

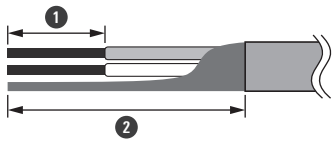

- ① Approx. 5 mm
- ② Approx. 20 mm

### 2 Loosen the screws with a flathead screwdriver.

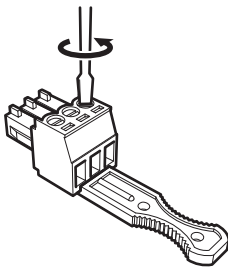

### 3 Check the pin assignments and connect each cable.

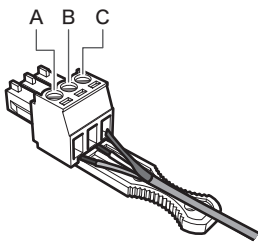

Terminal	Pin assignments
INPUT	A (+: Hot) B (-: Cold) C (G: Ground)
OUTPUT	A (+: Hot) B (-: Cold) C (G: Ground)
GPI	A (1: GPI1) B (2: GPI2) C (G: Ground)

### 4 Tighten the screws and use a zip tie to bundle the cables.

- Use a commercially available zip tie.

## Connection procedure

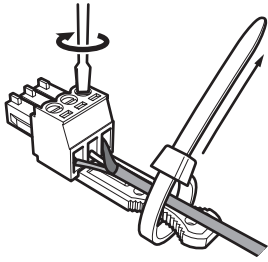

### 5 Connect the Euroblock connector to the microphone.

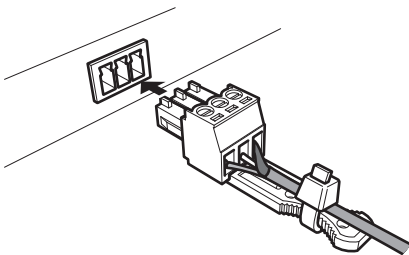

## GPI port

The function of the GPI port can be selected under "GPI Setting" in Digital Microphone Manager. The function assigned to the GPI port is executed by closing the GPI port and ground port. Close them for at least 0.5 seconds.

Item	Description
Mute	Mute (Open -> Close). Unmute (Close -> Open).
Power Save Mode	Turn power save mode on/off (Open -> Close).
Reboot	Reboot (Open -> Close).

# Reset button

Insert the tip of a pin or other thin device and press the reset button to reset the microphone.

- Resetting can be performed only during normal operating mode.  
Pressing the reset button while in power save mode will return to normal operating mode.

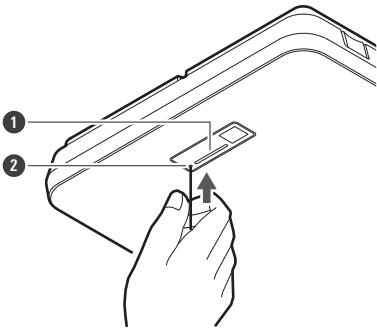

① Indicator lamp

② Reset button

## Checking the network mode

### 1 Press the reset button.

Indicator lamp	IP Config Mode setting
Flashes in green	Auto
Flashes in orange	Static

## Network reset

The following network settings will be reset.

- IP Control & Web Remote Port Settings
- Allow Discovery
- IP Control Settings

### 1 Press and hold the reset button for approximately 3 seconds.

» The indicator lamp will switch between being lit in red and orange.

### 2 Press the reset button while the indicator lamp is switching between being lit in red and orange.

- If there is no operation within 5 seconds of the indicator lamp switching between being lit in red and orange, the microphone will return to normal operating mode.

» The network reset will commence.

### Factory reset

Performing a factory reset will result in all settings being reset to factory default.

- 1 Press and hold the reset button for approximately 8 seconds.**
  - » **The indicator lamp will switch between being lit in green and orange.**
  
- 2 Press the reset button while the indicator lamp is switching between being lit in green and orange.**
  - If there is no operation within 5 seconds of the indicator lamp switching between being lit in green and orange, the microphone will return to normal operating mode.
  - » **The factory reset will commence. The microphone will automatically reboot upon completion of the factory reset.**



- During factory reset, leave the cable connected to the microphone.

# Digital Microphone Manager

Digital Microphone Manager is a software application that supports the operation of digital microphones (supported models) from Audio-Technica. It enables users to create projects, configure microphone and audio settings, as well as set a microphone coverage range that suits the layout of rooms where microphones are actually installed. It also enables users to perform real-time editing and display speaker positions in an online environment, a useful feature for on-site adjustments of advanced settings.

- Digital Microphone Manager is required to use this product.
- The installer can be downloaded from the Audio-Technica website (<https://www.audio-technica.com/>) for the country or region where used.
- After installing Digital Microphone Manager, launch it and configure the settings for this product.
- For details on settings, see the user manual -Digital Microphone Manager Edition-.



# Audio-Technica LINK

The ATND1061LK uses a proprietary format, "Audio-Technica LINK", to transmit audio signals and supply power between devices.

- Enables a daisy chain connection for multi-channel transmission.
- Enables high-speed signal transmission with low latency for stable control and transmission of multi-channel uncompressed audio signals.
- Enables multi-channel audio signals from the ATND1061LK to be individually assigned to mixer input channels.
- Enhances connectivity as it conforms to Ethernet standards and can be connected using a general-purpose LAN cable.



- Make sure to use a LAN cable of CAT5e or higher, a conductor with a diameter of 24AWG or larger, and a shield.



- Connections with the ATUC-50 series and the ATUC-IR series are not possible.

# Dante Controller (ATND1061DAN only)

- ATND1061DAN is compatible with Dante network audio. I/O settings for Dante devices can be set using Dante Controller (application provided by Audinate). For information on Dante Controller, visit the Audinate website (<https://www.audinate.com>).
- ATND1061DAN supports operation in AES67 mode. For use with AES67, enable AES67 mode on the Dante Controller and restart the microphone. For details, contact Audinate.

## Dante channel list

### Input (Dante Transmitter)

Name displayed on Dante Controller	Description
AEC Ref In	Inputs digital audio signals used as AEC reference signals.
Sum In	Used for auto mix when connecting multiple units. Inputs control signals from the main (Primary) microphone.
Chain In	Used for auto mix when connecting multiple units. Inputs control signals from the previous microphone in the chain.
Mix In	Used for auto mix when connecting multiple units. Used by the main (Primary) microphone to input auto mix signals from other (Follower) microphones.

### Output (Dante Receiver)

Name displayed on Dante Controller	Description
CH1	Coverage Zone audio output
CH2	Priority Zone audio output #1
CH3	Priority Zone audio output #2
CH4	Priority Zone audio output #3
CH5	Priority Zone audio output #4
CH6/AutoMix	Priority Zone audio output #5 or auto mix signal output (selection possible)
AEC Ref Out	Outputs AEC reference signals used with auto mix.
Sum Out	Used for auto mix when connecting multiple units. Outputs control signals to the next microphone.

# Web Remote

## What is Web Remote?

Web Remote is a web application used to control microphones. Web Remote enables the following remote control tasks to be performed from your Windows PC or Mac (hereinafter “control device”).

- Checking microphone status
- Changing microphone settings

## What is Locate?

Locate is a launcher application for Web Remote. Locate launches once a connection is established with a control device. Using Locate enables easy access to Web Remote as it eliminates the need for entering the IP address of the installed microphone.

- If you know the IP address of the microphone, Web Remote can also be launched without using Locate.

## Recommended environment

### OS for running Web Remote and Locate

- Microsoft Windows 10 or later
- macOS Big Sur or later

### Recommended web browsers for Web Remote

- Google Chrome (Windows)
- Mozilla Firefox (Windows)
- Safari (macOS)



- Up to three control devices can be logged into Web Remote simultaneously. However, if two different web browsers are running on one control device, that device will be counted as two.
- When ending Web Remote, make sure to log out before closing the web browser screen. Closing the screen without logging out may result in the session remaining active and you not being logged out of Web Remote.
- The minimum screen size for use with Web Remote is 1024 × 768 pixels. Use a display monitor for the control device that is large enough for the Web Remote screen to be displayed on a web browser.

# Preparation for Web Remote

## Connecting the microphone with the control device

- 1** Connect the control device with the microphone via a wired or wireless connection.
- 2** Perform network settings for the control device and connect to the network.



- The microphone ships from the factory with "IP Config Mode" set to "Auto". To connect using a static IP address, set "IP Config Mode" to "Static".

## Setting up Locate

- 1** Download the Locate installer and application to the control device.
  - The installer can be downloaded from the Audio-Technica website (<https://www.audio-technica.com/>) for the country or region where used.
- 2** Double-click the downloaded setup.exe.
  - » The setup wizard will appear.
- 3** Follow the on-screen instructions to install Locate.
  - » Once installed, a Locate icon will appear on the desktop.
- 4** Confirm that the microphone is connected to the same network as the control device before double-clicking on the Locate icon.
  - » Launch Locate. Microphones connected to the network are detected automatically.
- 5** Select the microphone to perform Web Remote control and click "Open".
  - » The Setting & Maintenance screen will appear.



- The "Identify" function is not available in Locate. Use Digital Microphone Manager for identifying connected microphones.

# Launching Web Remote

### Launch from Locate

- 1 Launch Locate installed to the control device.**
- 2 From the list, select the microphone for which Web Remote will be launched.**
  - » Once Web Remote is launched, the Setting & Maintenance screen will appear.

### Launch by directly specifying the IP address

If you know the IP address of the microphone, Web Remote can be launched by directly specifying the IP address.

- 1 Launch the web browser of the control device.**
- 2 Enter the IP address of the microphone for which Web Remote will be launched.**
  - » Once Web Remote is launched, the Setting & Maintenance screen will appear.

# Basic operations on Setting & Maintenance screen

This screen shows advanced settings for the entire system, as well as utilities for use during maintenance or when malfunctions occur.

- 1 Click ">" to open the settings menu and select settings.**

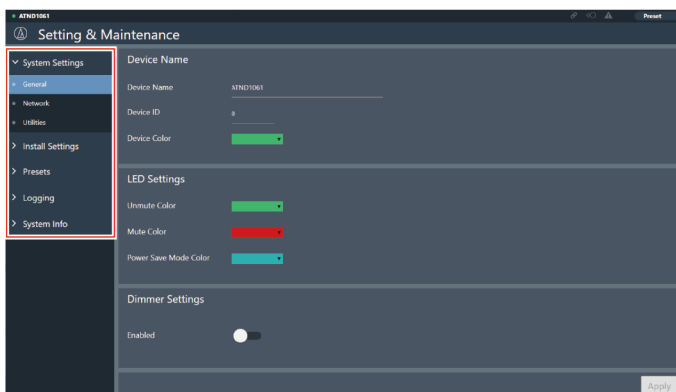

# Web Remote

**2** For settings requiring text input, click the field for the setting to input text.



**3** For settings requiring selection from a pull-down menu, click “▼” in the field for the setting and make a selection from the pull-down menu.

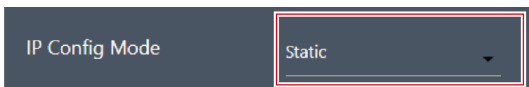

**4** For settings requiring use of a switch, click the switch.

- Switching between ON (blue) and OFF (no color) will occur with each click.



**5** For settings requiring the selection of values, click “▼” or “▲” in the field for the setting.

- The value will increase or decrease with each click.



**6** Click “Apply”.

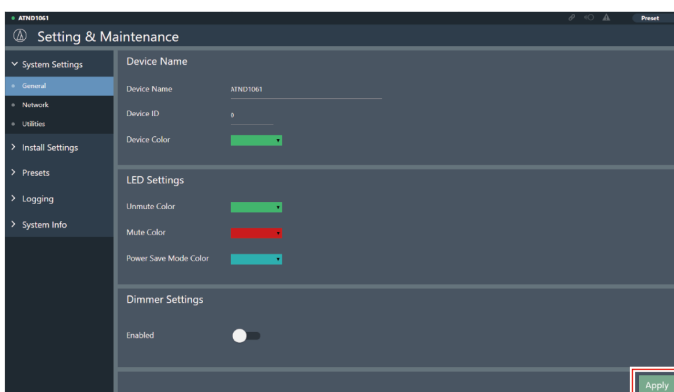

» The setting will be applied.

## General (System Settings)

### Device Name

Item	Description
Device Name	Set the microphone name.
Device ID	Set the microphone ID.
Device Color	Set display colors for microphones on Digital Microphone Manager.

### LED Settings

Item	Description
Unmute Color	Set indicator lamp colors for microphones when unmuted.
Mute Color	Set indicator lamp colors for microphones when muted.
Power Save Mode Color	Set indicator lamp colors for microphones when in power save mode.

### Dimmer Settings

Item	Description
Enabled	Set the brightness of the microphone indicator lamp. When set to "ON" (blue), the microphone indicator lamp will dim.

## Network (System Settings)

### Network Configuration (ATND1061DAN only)

Item	Description
Mode	Output is performed via a single cable when set to "Single cable". Output of IP control is performed via a separate cable when set to "Split". Because this will require multiple connections, ensure that the necessary connections are made.
Latency	Set latency for the Dante port.

### Dante & Audio Port Settings (ATND1061DAN only)

Item	Description
IP Config Mode	Set the configuration mode for the IP address. When "Auto" is selected, IP addresses are automatically assigned by DHCP servers, etc. When "Static" is selected, static IP addresses are used.
IP Address <sup>[1]</sup>	Set the IP address.
Subnet Mask <sup>[1]</sup>	Set the subnet mask.
Gateway Address <sup>[1]</sup>	Set the gateway address.

[1] This is possible when "IP Config Mode" is set to "Static".

### IP Control & Web Remote Port Settings

Item	Description
IP Config Mode	Set the configuration mode for the IP address. When "Auto" is selected, IP addresses are automatically assigned by DHCP servers, etc. When "Static" is selected, static IP addresses are used.
IP Address <sup>[1]</sup>	Set the IP address.
Subnet Mask <sup>[1]</sup>	Set the subnet mask.
Gateway Address <sup>[1]</sup>	Set the gateway address.

[1] This is possible when "IP Config Mode" is set to "Static".

### Allow Discovery

Item	Description
Enabled	Set automatic detection for microphones on the same network. Automatic detection is possible when set to "ON" (blue).



## IP Control Settings

Item	Description
Port Number	Shows the IP control port number.
Notification	Set whether to receive notifications from microphones during IP control. Notifications will be received when set to "ON" (blue).
Audio Level Notification <sup>[1]</sup>	Set whether to receive audio level notifications from microphones during IP control. Setting to "ON" (blue) will result in notifications being received.
Camera Control Notification <sup>[1]</sup>	Set whether to receive notifications regarding whether sound has entered the set camera area from microphones during IP control. Setting to "ON" (blue) will result in notifications being received.
Multicast Address <sup>[1]</sup>	Set the address for multicast.
Multicast Port Number <sup>[1]</sup>	Set the port number for multicast.

[1] This is possible when "Notification" is set to "ON".

## Utilities (System Settings)

### Firmware Update

Use this procedure to update microphone firmware.

- 1 Use the "Serial No.", "Device Name", and "Firmware Ver." shown on the screen to determine whether the microphone is subject to an update.
- 2 Click "Browse".

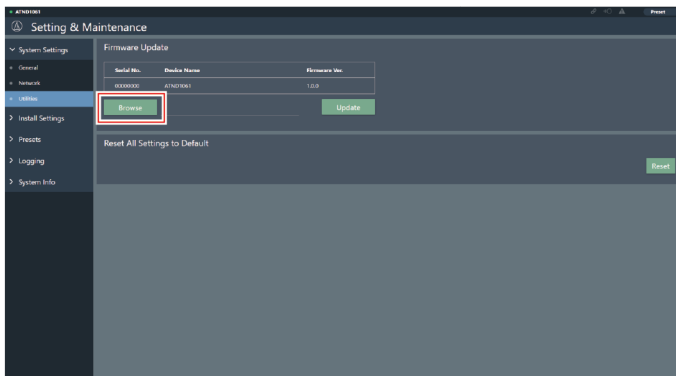

- 3 Select a file to be updated from the file selection screen.

## 4 Click "Update".

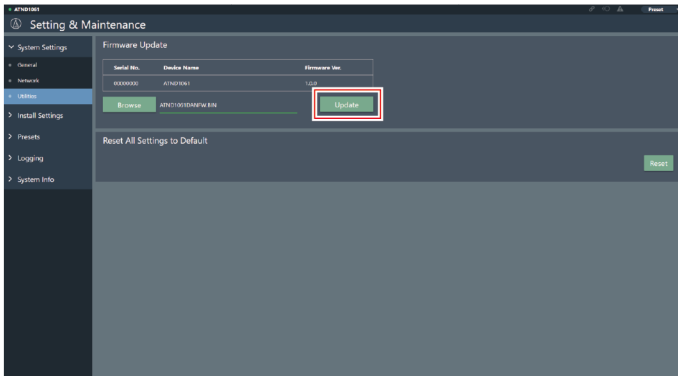

» The update will start. Once the update is complete, a completion screen will appear and the microphone will automatically reboot.

## Reset All Settings to Default

All microphone settings will be reset to factory default.

- However, the firmware version will remain the same.

## 1 Click "Reset".

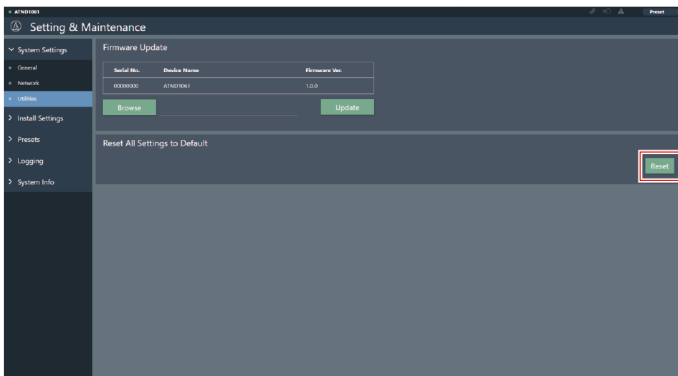

## 2 Check the confirmation screen and click "Yes".

» Once initialization is complete, a completion screen will appear.

## Audio (Install Settings)

### Beam CHs

Configure audio settings for CH1 to CH6.

Item	Description
Input Gain	Set the input gain of the audio input.
Low Cut	Set whether to cut the low-pass range of the input audio. Setting to "ON" (blue) will cut the low-pass range of the input audio.
4Band EQ	Set whether to apply 4-band EQ to the audio input. Setting to "ON" (blue) will apply this function.
Level	Set the level of audio input.
Mute	Set whether to mute or unmute. Setting to "ON" (blue) will mute audio.
Gain Share	Set whether to enable auto mix. Setting to "ON" (blue) will enable this function.

### Analog Input

Item	Description
Input Type	Set the input type of the analog input channel.
Phantom <sup>[1]</sup>	Set whether to enable phantom power. Setting to "ON" (blue) will enable this function.
4Band EQ	Set whether to apply 4-band EQ to the audio input. Setting to "ON" (blue) will apply this function.
Level	Set the level of audio input.

[1] This is possible when "Input Type" is set to "Mic".

### DSP Mode

Item	Description
DSP Mode	Set DSP mode for audio settings.

### Auto Mix CH

Item	Description
AEC	Set whether to enable the acoustic echo canceler. Setting to "ON" (blue) will enable this function.
AEC Reference	Set the reference signal. Normally, audio from a microphone at another site would be selected.
NC	Set whether to enable noise cancellation. Setting to "ON" (blue) will enable this function.
AGC	Set whether to enable auto gain control. Setting to "ON" (blue) will enable this function.
Level	Set the level of audio output.

### Analog Output

Item	Description
Unity	Set the unity level.
Level	Set the level of audio output.

### Voice Lift CH

Displayed only when "DSP Mode" is set to "Voice Lift Mode".

Item	Description
Processing Level	Set the suppression strength of the voice lift function.
Input Gain	Set the input gain of the audio input.
4Band EQ	Set whether to apply 4-band EQ to the audio input. Setting to "ON" (blue) will apply this function.
Level	Set the level of audio input.

### Dante Tx#6 Signal (ATND1061DAN only)

Item	Description
Dante Tx#6 Signal	The assignment of the 6th digital output can be changed. If set to "CH6", mixing will take place using equipment at a later stage. If set to "Automix", the mixing function of the microphone will be used.

## Camera

### Device

Item	Description
Enabled	Set the camera linking function. Setting to "ON" (blue) will enable the camera linking function.
Protocol <sup>[1]</sup>	Select the protocol to be used.
IP Address <sup>[1]</sup>	Enter the IP address of the camera to be used.
Port Number <sup>[1]</sup>	Set as follows depending on the protocol to be used. VISCA over IP: 52381 Panasonic: Port number set on the camera

[1] This is possible when "Enabled" is set to "ON" (blue).

### Talk Setting

Item	Description
Talk To Recall Preset	Set the number of seconds after a speaker starts talking before the camera preset is recalled (the camera moves). Set this function to prevent the camera from moving immediately whenever a short utterance is made, etc.

### Silent Setting

Item	Description
Enabled	Set a silent time. Setting to "ON" (blue) will enable the silent time setting.
Time To Go Back Home <sup>[1]</sup>	Set the number of seconds of silence before the camera preset is recalled (the camera returns to a position). Set this function to project the entire scene instead of focusing on a specific person when there is silence.
Position <sup>[1]</sup>	Set where the camera will return when there is silence.

[1] This is possible when "Enabled" is set to "ON" (blue).

### Camera Preset

Configure settings to link the camera area group with the preset recalled by the camera. Check the camera preset number and set which camera preset to recall.

## Presets

### Presets

Item	Description
Preset Name	Display the preset name.
Boot Up Preset	Set the presets to be recalled when the microphone boots.

### Exporting presets

Export presets to a file.

- 1 Click the button(s) of the preset(s) to be exported to a file.

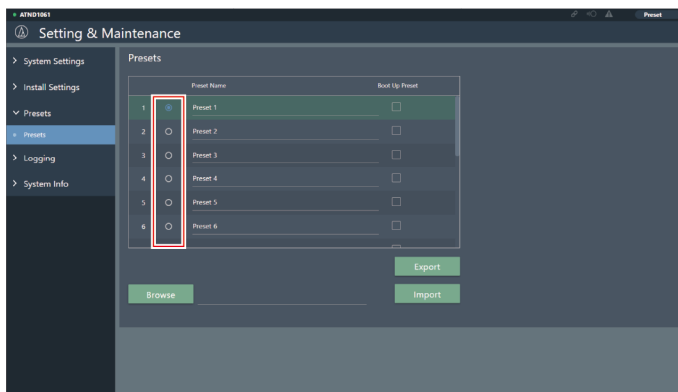

- 2 Click "Export".

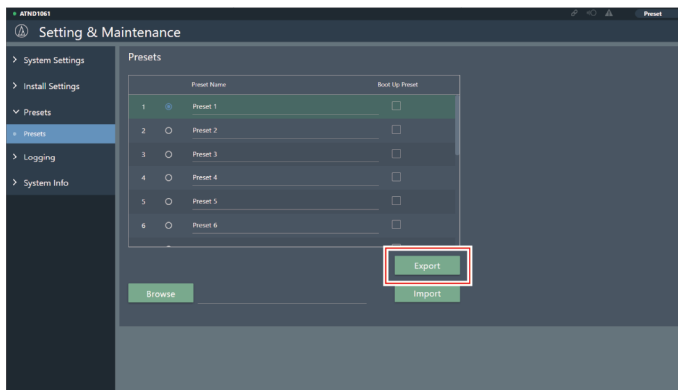

- 3 Export after specifying the export location and file name.

## Importing presets

Import exported preset files.

- 1 Click the button(s) of the import destination preset(s).

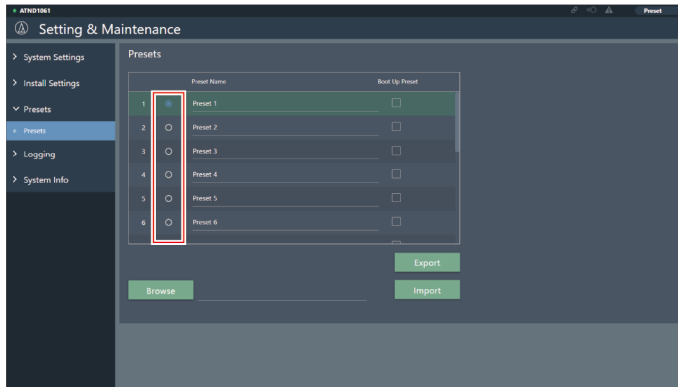

- 2 Click "Browse".

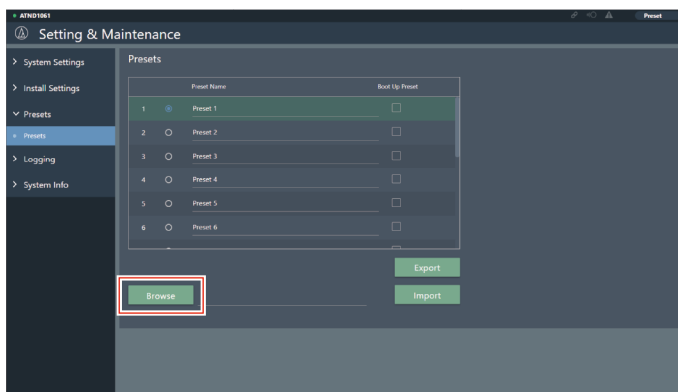

- 3 Select and open preset files from the file selection screen.
- 4 Click "Import".

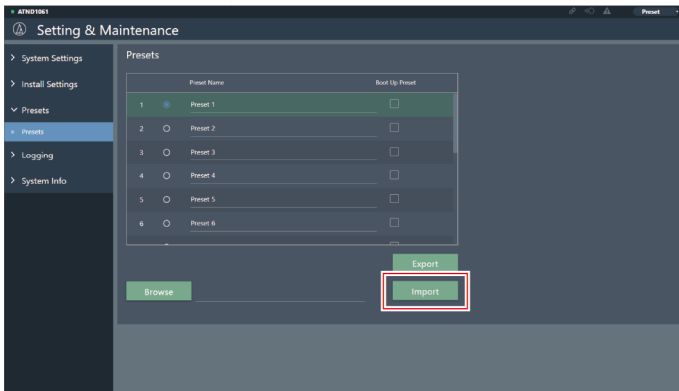

» The preset(s) will be imported.

## Logging

Perform settings for log messages and download log files.

Item	Description
Enabled	Set whether to save log messages. Setting to "ON" (blue) will save log messages.
Destination <sup>[1]</sup>	Set whether to write log messages to internal memory or forward them to a Syslog server.
Log File	Clicking "Download" will download log files registered to internal memory.

[1] This is possible when "Enabled" is set to "ON".



- Syslog is a standard for forwarding log messages over IP networks. It is used to manage computer systems and monitor security.

## System Info

This displays information about the system, such as network settings and the serial number and firmware version of the microphone. System information can be exported to a text file by clicking "Export".

## Header

The header on the top of the screen displays statuses and preset names.



# Web Remote

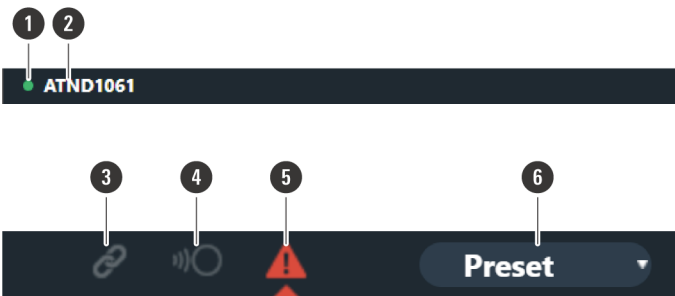
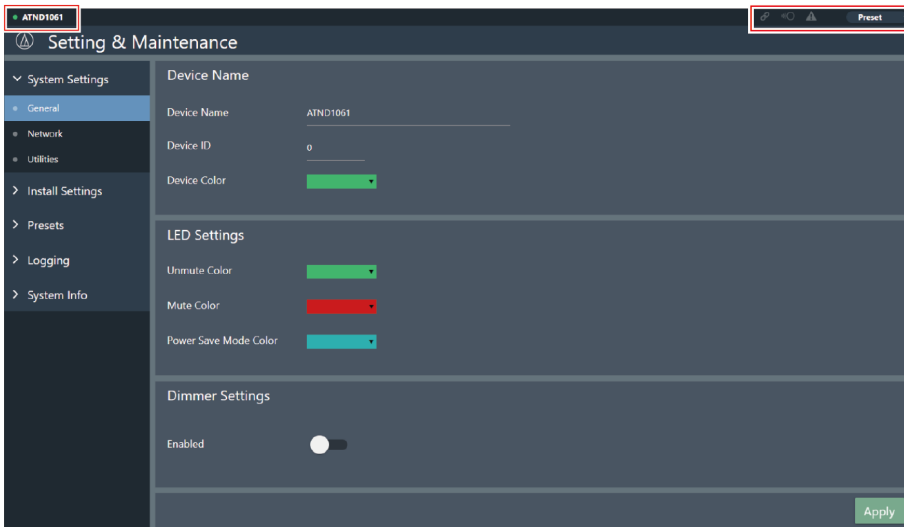

## 1 Microphone color

This mark is displayed when operating multiple microphones.

## 2 Microphone name

The name set for the device is displayed.

## 3 Audio-Technica LINK status (ATND1061LK only)

Displays the Audio-Technica LINK connection status.



: Audio-Technica LINK is not connected correctly.



: Audio-Technica LINK is connected correctly.



: There is an Audio-Technica LINK error.

## 4 IP remote status

Indicates that control is being performed via IP.



: Not under remote control.



: Under remote control.



: There is a remote control error.

## Web Remote

### 5 Error status

Displays the error status.



: No error is present.



: An error is present.

### 6 Presets

Displays the preset selection and name of the imported preset(s).

## Displaying descriptions of errors

If a triangle mark is displayed in the icon, click on the icon to display a description of the error. After checking the description of the error, move the cursor away from the icon, and the triangle mark will disappear.



## Presets

Up to 16 presets can be saved, including for beam zones, audio, camera areas, and some settings in Setting & Maintenance set using Web Remote or Digital Microphone Manager. This enables settings to be switched to suit user needs.

## Saving presets

### 1 Click "Preset".

- "Preset" shows the name of the current preset.

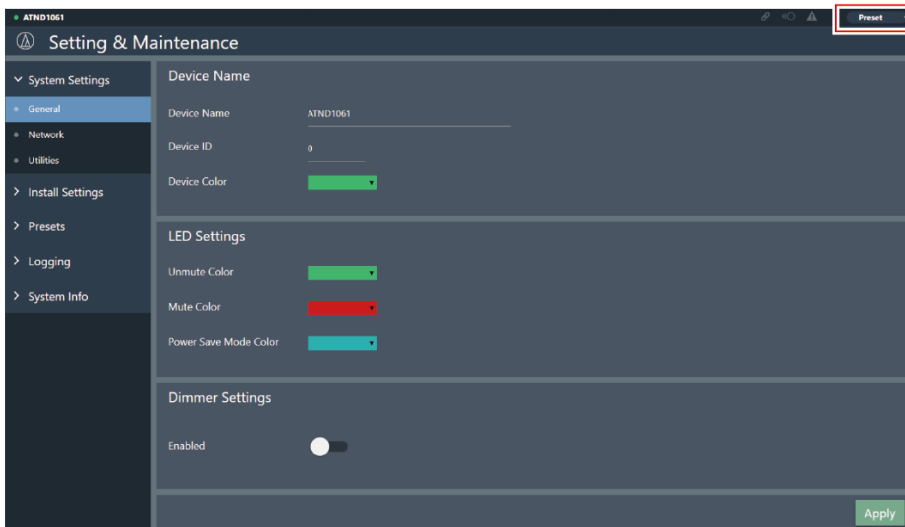

**2** Click "Save Preset" in the pull-down menu.

**3** Click the slot where the preset is to be saved.

**4** Enter a name.

**5** Click "Save".

- It may take several minutes to save presets.

» **Settings for the microphone are saved in the preset.**



- For information on importing and exporting presets, see "Presets" (p. 69) in Setting & Maintenance.

## Recalling presets

**1** Click "Preset".

- "Preset" shows the name of the current preset.

# Web Remote

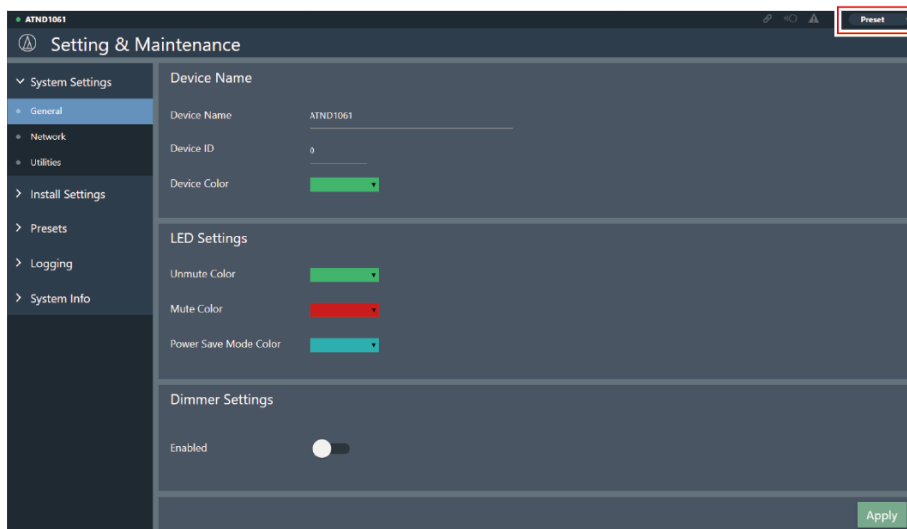

**2** Click "Recall Preset" in the pull-down menu.

**3** Click the preset to be recalled.

» The preset is reflected in the microphone settings.

# Function List

Item		Setting values	Default Setting	Presets Included	Resumed	Web Remote
Device Name	Device Name	(Maximum 30 characters (ASCII code only))	ATND1061	-	✓	✓
	Device ID	1 to 999	0	-	✓	✓
	Device Color	Green, Yellow, Red, Pink, Blue, Cyan	Green	-	✓	✓
Command Link	Preset Link	On, Off	On	-	✓	-
	Mute Link	On, Off	On	-	✓	-
	Power Save Mode Link	On, Off	On	-	✓	-
	Link Group	1 to 128	1	-	✓	-
GPI Settings	Port1	Mute, Power Save Mode, Reboot, Camera Control	Mute	✓	✓	-
	Port2	Mute, Power Save Mode, Reboot, Camera Control	Power Save Mode	✓	✓	-
Dante Network Configuration <sup>[1]</sup>	Mode	Single Cable, Split	Single Cable	-	✓	✓
	Latency	0.25 msec, 0.5 msec, 1 msec, 2 msec, 5 msec	0.5 msec	-	✓	✓
Dante & Audio Port Settings <sup>[1]</sup>	IP Config Mode	Auto, Static	Auto	-	✓	✓
	IP Address	0.0.0.0 to 255.255.255.255	-	-	✓	✓
	Subnet Mask	0.0.0.0 to 255.255.255.255	-	-	✓	✓
	Gateway Address	0.0.0.0 to 255.255.255.255	-	-	✓	✓
IP Control & Web Remote Port Settings	IP Config Mode	Auto, Static	Auto	-	✓	✓
	IP Address	0.0.0.0 to 255.255.255.255	-	-	✓	✓
	Subnet Mask	0.0.0.0 to 255.255.255.255	-	-	✓	✓
	Gateway Address	0.0.0.0 to 255.255.255.255	-	-	✓	✓
Allow Discovery	Enabled	On, Off	On	-	✓	✓
IP Control Settings	Port Number	00001 to 65535	17300	-	✓	✓

## Function List

Item		Setting values	Default Setting	Presets Included	Resumed	Web Remote	
	Notification		On, Off	Off	-	✓	✓
	Audio Level Notification		On, Off	Off	-	✓	✓
	Camera Control Notification		On, Off	Off	-	✓	✓
	Multicast Address		0.0.0.0 to 255.255.255.255	239.0.0.100	-	✓	✓
	Multicast Port Number		00001 to 65535	17000	-	✓	✓
Beam Settings	Beam Sensitivity		Low, Mid, High	Mid	✓	✓	-
	Auto Attenuation		On, Off	On	✓	✓	-
	Attenuation Level		-∞ dB to -3.0 dB	-14.0 dB	✓	✓	-
	Hold Time		0.0 sec to 10.0 sec	1.5 sec	✓	✓	-
DSP Mode	DSP Mode		AEC Mode, Voice Lift Mode	AEC Mode	✓	✓	✓
Dante Tx#6 Signal <sup>11</sup>	Dante Tx#6 Signal		Priority 5, Auto Mix	Auto Mix	✓	✓	✓
LED Settings	Unmute Color		Black (No light), Red, Orange, Yellow, Pink, Purple, Blue, Aqua, Green, Cyan, White	Green	✓	✓	✓
	Mute Color		Black (No light), Red, Orange, Yellow, Pink, Purple, Blue, Aqua, Green, Cyan, White	Red	✓	✓	✓
	Power Save Mode Color		Black (No light), Red, Orange, Yellow, Pink, Purple, Blue, Aqua, Green, Cyan, White	Cyan	✓	✓	✓
LED Dimmer	LED Dimmer		On, Off	Off	✓	✓	✓
Allow Control	Mute		On, Off	On	✓	✓	-
	Power Save Mode		On, Off	On	✓	✓	-
	Preset		On, Off	On	✓	✓	-
Presets	Preset Name		(Maximum 30 characters)	Preset 1 to 16	✓	✓	✓

## Function List

Item		Setting values	Default Setting	Presets Included	Resumed	Web Remote	
	Boot Up Preset		1 to 16, Non	-	✓	✓	
Device	Enabled		On, Off	Off	✓	✓	
Talk Setting	Time To Recall Preset		0.5 sec to 10.0 sec	0.5 sec	✓	✓	
Silent Setting	Enabled		On, Off	On	✓	✓	
	Time To Go Back Home		0.5 sec to 100.0 sec	0.5 sec	✓	✓	
	Position		Home, Preset 1 to Preset 100	Home	✓	✓	
Logging	Enabled		On, Off	On	✓	✓	
	Destination		Internal, Syslog	Internal	✓	✓	
Device	Position (feet/mm)	X		X: 16.4 feet/5000 mm	✓	-	
		Y		Y: 16.4 feet/5000 mm	✓	-	
	Altitude		3.3 feet/1,000 mm to room height	Room height	✓	-	
Channel Settings	Beam CH 1 to 6	CH #	Coverage, Priority 1 to 5	-	-	✓	
		Input Gain	0 dB to +30 dB	0 dB	✓	✓	
		Lowcut	On, Off	Off	✓	✓	
		4 Band EQ	On, Off	Off	✓	✓	
		CH Name	(Maximum 10 characters)	Coverage: CH1 Priority 1 to 5: CH2 to 6	✓	✓	-
		CH Color	Green, Yellow, Brown, Red, Pink, Blue, Gray, Dark Gray	CH1: Green CH2: Yellow CH3: Brown CH4: Red CH5: Pink CH6: Blue	✓	✓	-
		Level	$-\infty$ , -120.0 dB to +10.0 dB	0.0 dB	✓	✓	✓
		CH Mute	On, Off	Off	✓	✓	✓
	Analog Input	Mode Select	Mic, Line	Line	✓	✓	✓
		Input Gain	Mode = When Mic: +0.25 dB, Mode = When Line: +0.5 dB	0.5 dB (because Mode = Line Default)	✓	✓	-
4 Band EQ		On, Off	Off	✓	✓	✓	

## Function List

Item		Setting values	Default Setting	Presets Included	Resumed	Web Remote	
		CH Name	(Maximum 10 characters)	Analog In	✓	✓	-
		Level	$-\infty$ , -120.0 dB to +10.0 dB	0.0 dB	✓	✓	✓
		Phantom	On, Off	Off	-	-	✓
	Auto Mix	CH Name	(Maximum 10 characters)	Auto Mix	✓	✓	-
		CH Mute	On, Off	Off	✓	✓	-
		Level	$-\infty$ , -120.0 dB to +10.0 dB	0.0 dB	✓	✓	✓
	Analog Output	CH Name	(Maximum 10 characters)	Analog Out	✓	✓	-
		Unity	+4 dBu, -10 dBV, -33 dBV	+4 dBu	✓	✓	✓
		Level	$-\infty$ , -120.0 dB to +10.0 dB	0.0 dB	✓	✓	✓
		CH Mute	On, Off	Off	✓	✓	-
	Auto Mix <sup>[2]</sup>	Enabled	On, Off	Off	✓	✓	✓
		Weight	-15.0 to 15.0	0.0	✓	✓	-
Gain Share Mode		Stand Alone, Link	Stand Alone	✓	✓	-	
4 Band EQ <sup>[3]</sup>	Mode Change		Easy Mode, Expert Mode	Expert Mode	-	✓	-
	Easy Mode	Type Select	High, Mid, Low	Mid	✓	✓	-
		Tone	Warm, Warm-1, Warm-2, Warm-3, Warm-4, Warm-5, Warm-6, Neutral, Bright-6, Bright-5, Bright-4, Bright-3, Bright-2, Bright-1, Bright	Neutral	✓	✓	-
	Expert Mode	Band#1 Frequency	20 Hz to 20000 Hz	25	✓	✓	-
		Band#1 Gain	-18 dB to +18 dB	0	✓	✓	-
		Band#1 Q value	0.3 to 60	0.75	✓	✓	-
		Band#1 Filter type	HPF, LSH, PEQ	PEQ	✓	✓	-
Band#2 Frequency	20 Hz to 20000 Hz	63 Hz	✓	✓	-		



## Function List

Item		Setting values	Default Setting	Presets Included	Resumed	Web Remote	
	Band#2 Gain	-18 dB to +18 dB	0 dB	✓	✓	-	
	Band#2 Q value	0.3 to 60	0.75	✓	✓	-	
	Band#3 Frequency	20 Hz to 20000 Hz	6300 Hz	✓	✓	-	
	Band#3 Gain	-18 dB to +18 dB	0 dB	✓	✓	-	
	Band#3 Q value	0.3 to 60	0.75	✓	✓	-	
	Band#4 Frequency	20 Hz to 20000 Hz	16000 Hz	✓	✓	-	
	Band#4 Gain	-18 dB to +18 dB	0 dB	✓	✓	-	
	Band#4 Q value	0.3 to 60	0.75	✓	✓	-	
	Band#4 Filter type	LPF, HSH, PEQ	PEQ	✓	✓	-	
AEC	AEC		On, Off	Off	✓	✓	✓
	AEC Reference		Analog Input, Digital Input	Analog Input	✓	✓	✓
	NLP		On, Off	Off	✓	✓	-
	NLP Sensitivity		Low, Mid, High	Mid	✓	✓	-
NC	NC		On, Off	Off	✓	✓	✓
	NC Attenuation Level		0 to 20	6	✓	✓	-
AGC	AGC		On, Off	Off	✓	✓	✓
	Target Level		-10 to 10	0	✓	✓	-

[1] Only displayed for ATND1061DAN.

[2] Capable of being set individually to Coverage and Priority 1 to Priority 5.

[3] Capable of being set individually to Coverage, Priority 1 to Priority 5, and Analog Input.

# Troubleshooting

Please check the following when problems with the microphone occur. Also see the user manual -Digital Microphone Manager Edition-

- Check whether the microphone is connected correctly.
- Check whether the microphone is operating as described in the user manual.
- Check whether external devices are operating correctly. Perform this check with the microphone disconnected.
- Restart network devices.

## ? Microphone doesn't turn on

- Check whether the port for Network A on the back of the microphone is securely connected to the PoE switching hub using a LAN cable. (ATND1061DAN only)
- Check whether the PoE switching hub is operating correctly. (ATND1061DAN only)
- Check whether power is being supplied to the ATLK-EXT25. (ATND1061LK only)
- Make sure to use a LAN cable of CAT5e or higher, a conductor with a diameter of 24AWG or larger, and a shield.

## ? Microphone is not recognized by Digital Microphone Manager or Web Remote

- Check whether the microphone and computer are connected to the same network.
- Review firewall settings.
- Check Digital Microphone Manager and Web Remote to see whether "Allow Discovery" > "Enabled" is set to "ON".

## ? Microphone is not recognized by Dante Controller (ATND1061DAN only)

- Check Digital Microphone Manager to see whether settings for "Dante Network Configuration" > "Mode" are correct.
- Check whether the Dante audio connected to the port for Network A on the back of the microphone is connected to the same network as the connected Dante device.

## ? No sound emitted from microphone

- Check whether the beam output (Dante transmitter) is correctly routed to the Dante receiver of the output device using Dante Controller. (ATND1061DAN only)
- Check Digital Microphone Manager to see whether the Exclusion Zone has been set.
- Check whether the audio I/O level is set to "-∞" (minimum value) in the audio settings of Digital Microphone Manager.
- Check whether any beam channels are muted.

## Troubleshooting

- If using an Auto Mix channel for output, check whether the auto mix settings for each beam channel in Digital Microphone Manager are correct.

### ? No sound emitted from analog output

- Check whether the analog I/O ports on the back of the microphone are connected correctly.
- Check whether the pin assignments for the analog I/O ports on the back of the microphone are correct.

### ? Strange noises are emitted

- Check whether the target zone is set to the effective range in the beam settings of Digital Microphone Manager.
- Check whether the 4-band EQ settings of Digital Microphone Manager are correct.
- Check whether the position and orientation of the microphone are correct for the room.

### ? Indicator lamp does not light

- Check Digital Microphone Manager to see whether “LED Settings” is set to black (not lit).

### ? AEC does not function

- Check Digital Microphone Manager and Web Remote to see whether settings for “AEC” > “AEC Reference” are correct.
- Check whether far end audio is routed to “AEC Ref In” of the microphone’s Dante receiver using Dante audio routing. (ATND1061DAN only)

### ? Preset settings do not sync between multiple microphones

- Check Digital Microphone Manager to see whether “General” > “Command Link” > “Preset Link” is set to “ON” for all microphones.

### ? IR remote controller does not operate

- Check whether the battery is installed in the correct orientation.
- Check whether the battery is dead. Replace the battery if dead.
- Check Digital Microphone Manager to see whether “IR Receiver” > “Allow Control” is set to “ON”.

### ? IP control is not possible

- Check whether the microphone and computer are connected to the same network.

- Check whether the port No. used for IP control is correct.

### **① No incoming IP control notifications**

- Check Digital Microphone Manager and Web Remote to see whether “IP Control Settings” > “Notification” is set to “ON”.

### **① Camera does not operate**

- If the indicator lamp on the microphone flashes in red (in 2 second intervals), communication with the camera is not established. Check whether the camera’s power supply is on. Also, check whether the microphone and camera are connected to the same network.
- If the camera does not operate even though the indicator lamp on the microphone is not flashing in red (in 2 second intervals), check whether the camera area and camera presets have been set correctly. Also, check Digital Microphone Manager and Web Remote to see whether “Camera” > “Enabled” is set to “ON”.

# Dimensions

## ATND1061LK

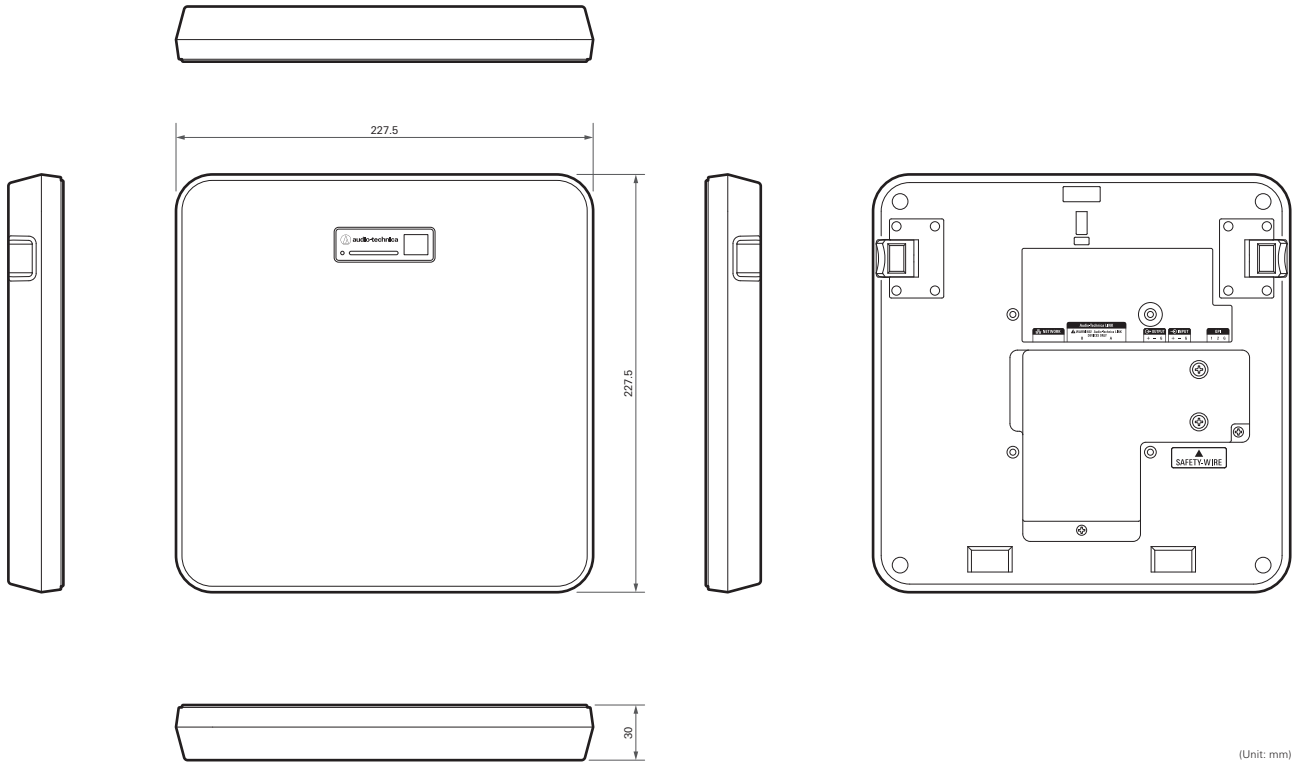

(Unit: mm)

# Dimensions

## ATND1061DAN

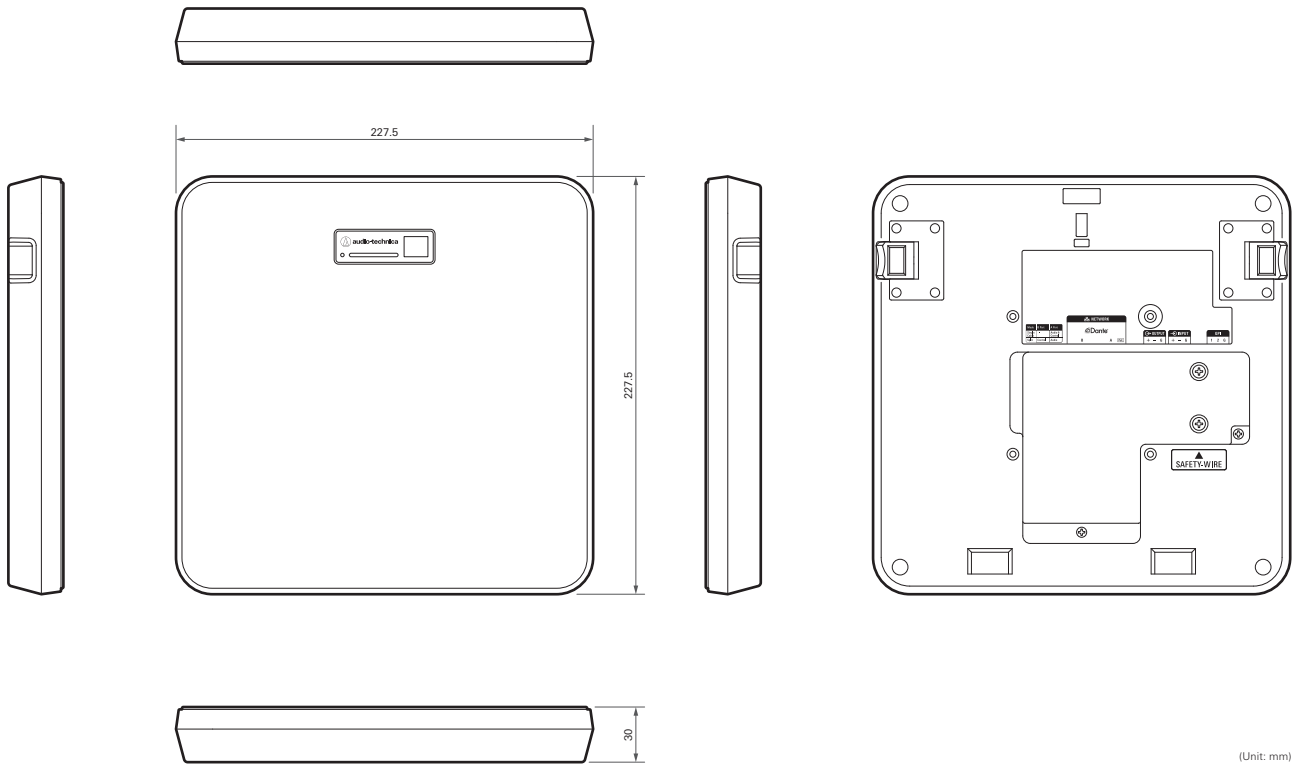

(Unit: mm)

# Dimensions

## Surface mount adapter

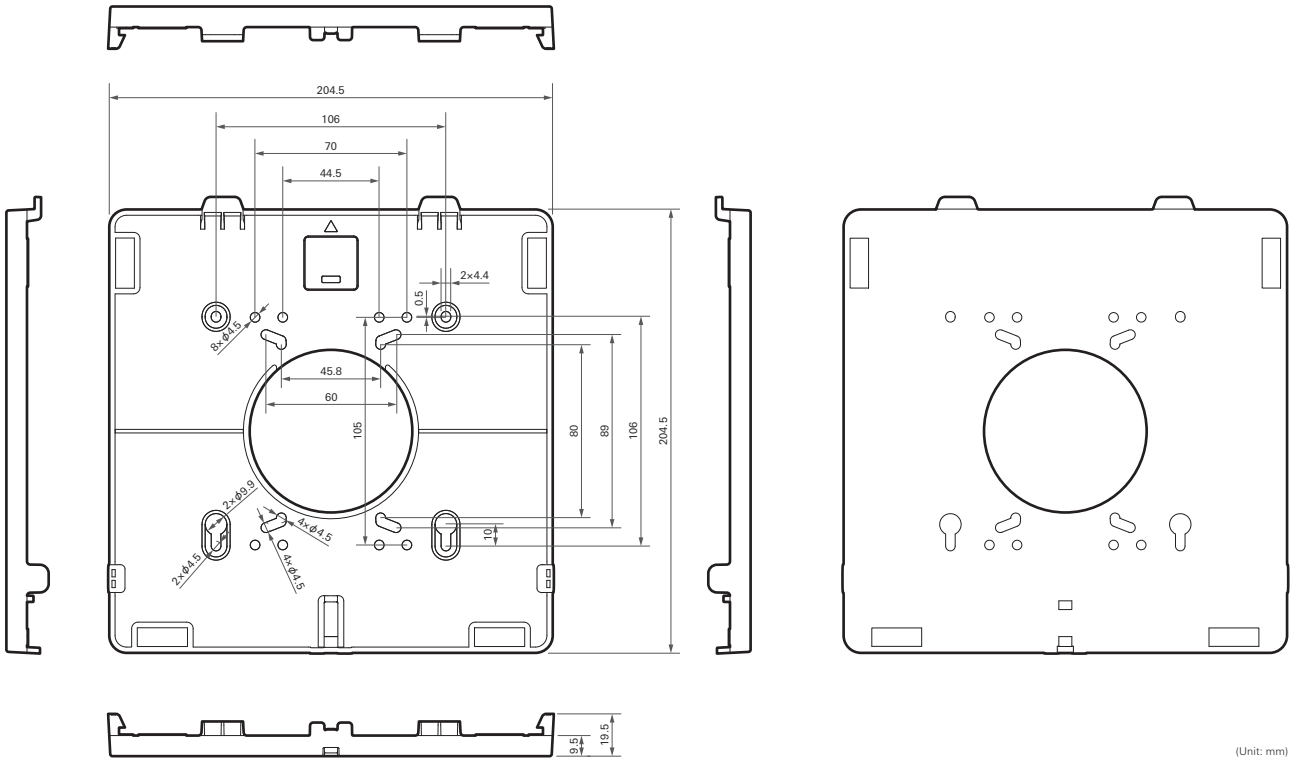

# Dimensions

## Flush mount adapter

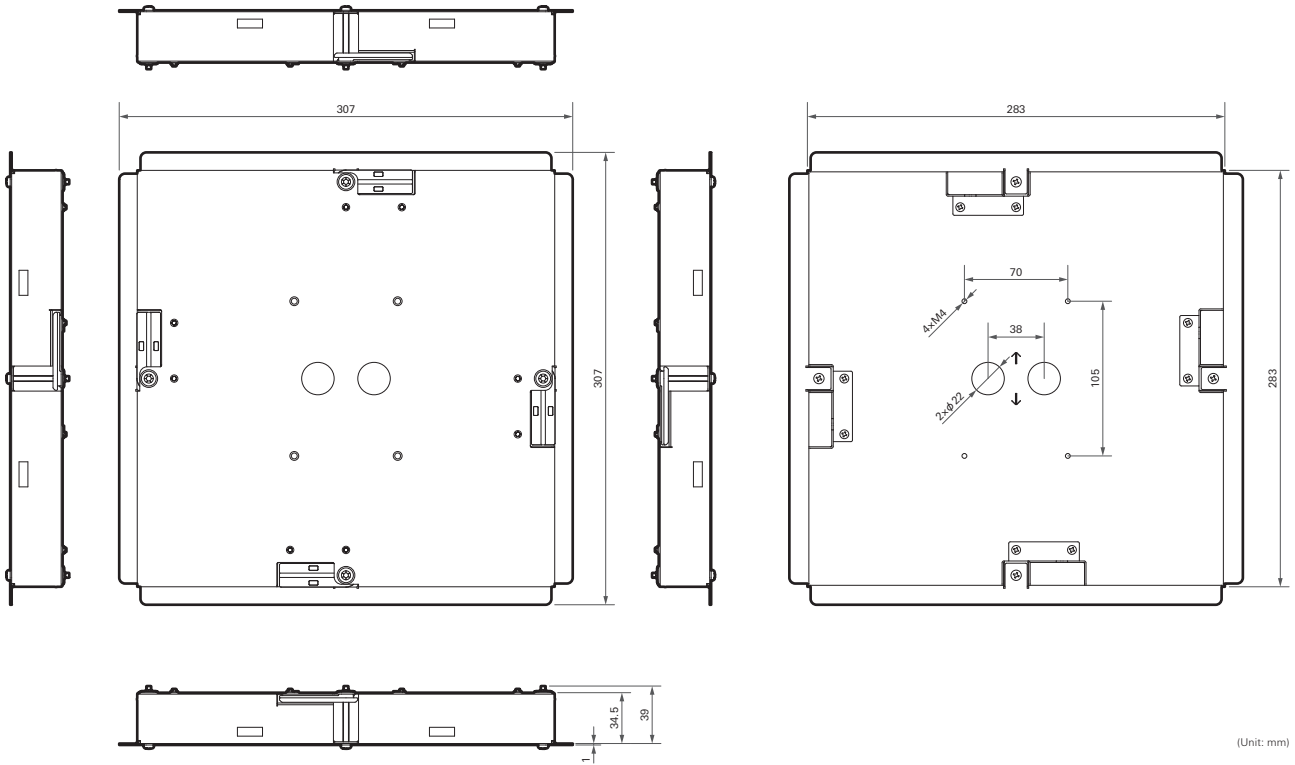



# Dimensions

## Flush mount cover

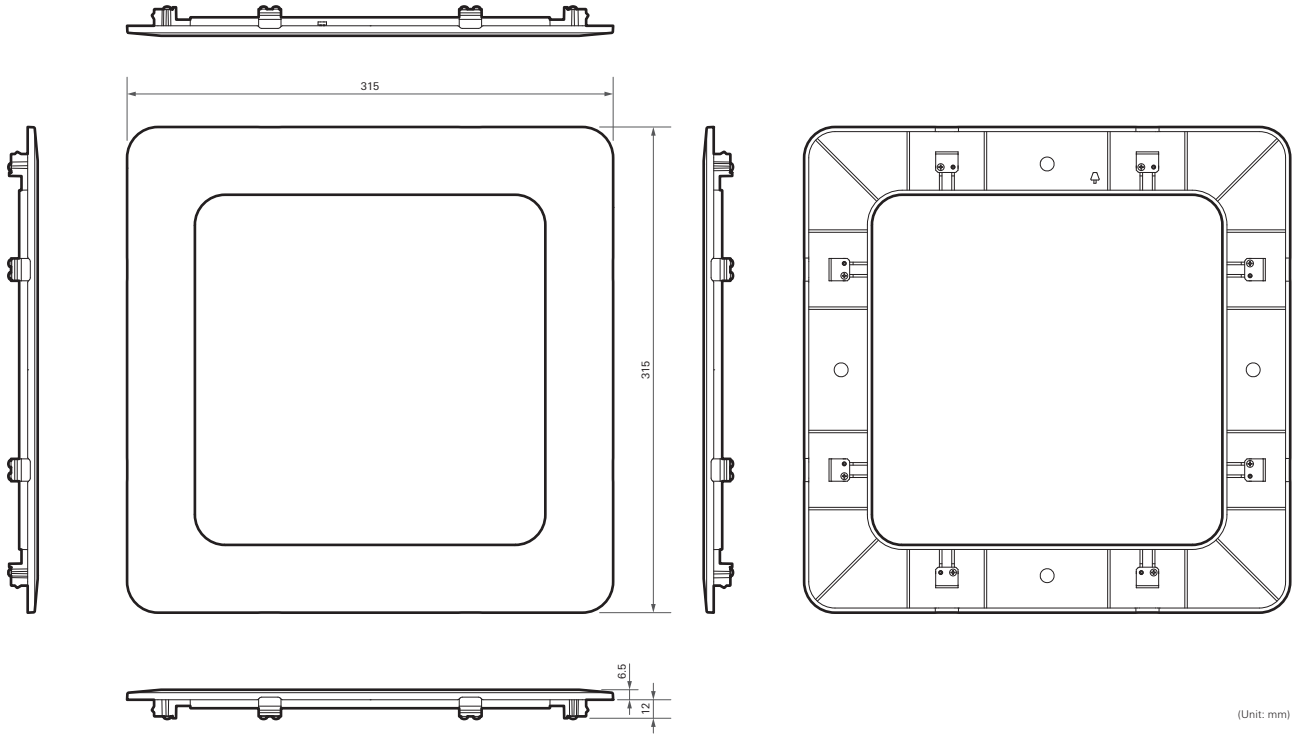

## Tile bridge A

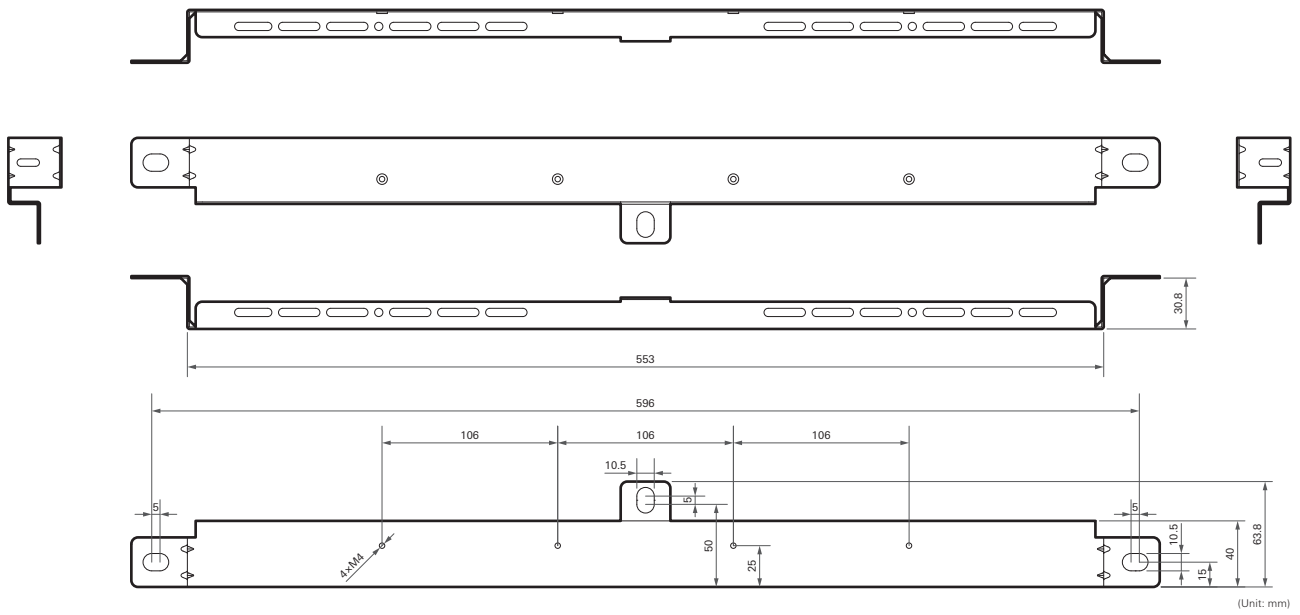

# Dimensions

## Tile bridge B

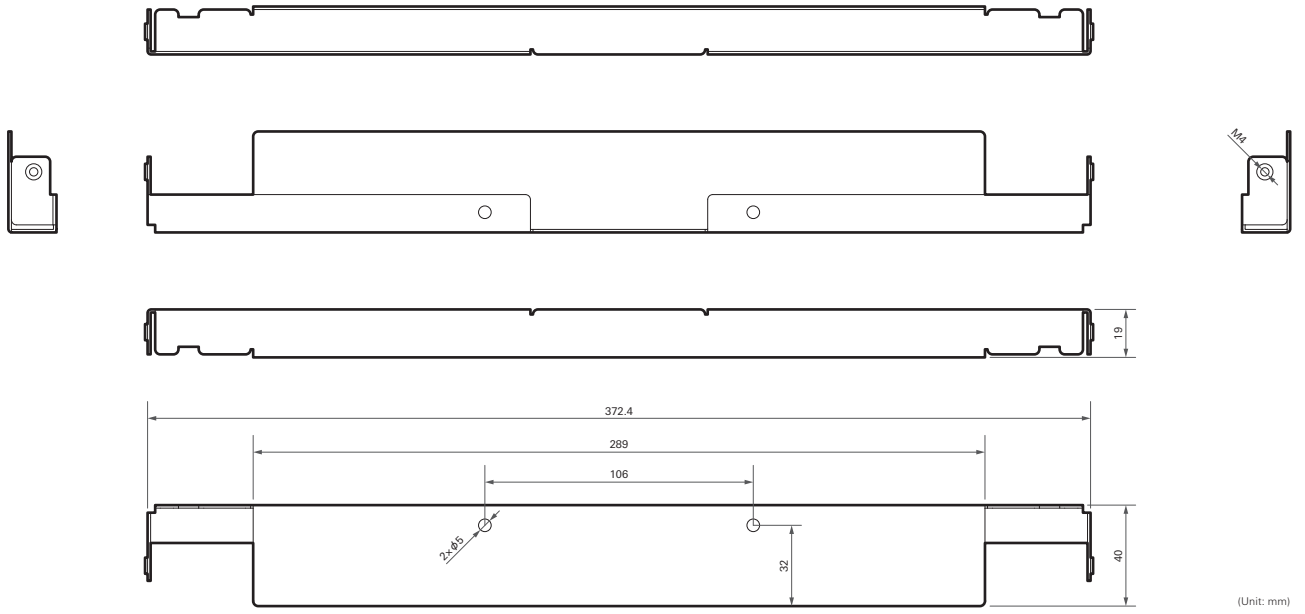

## Tile bridge C

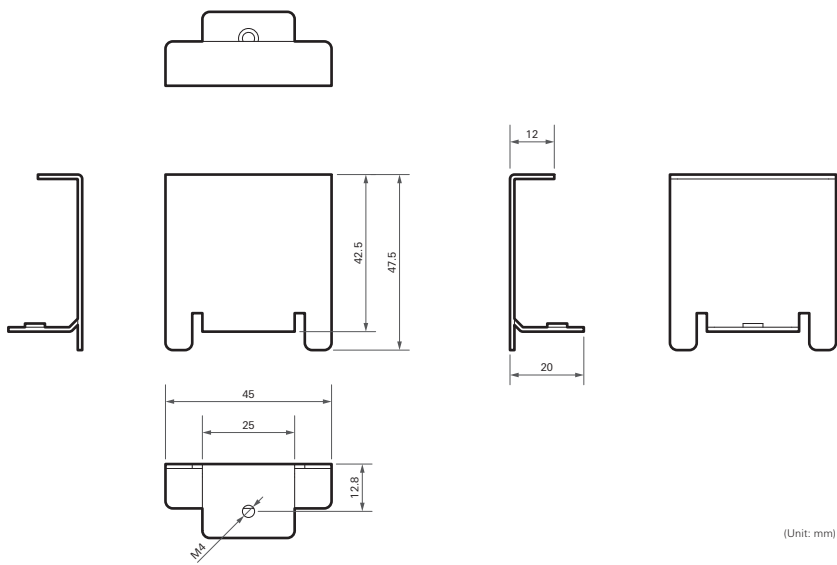

# Dimensions

## Assembly diagram of tile bridge for grid ceiling

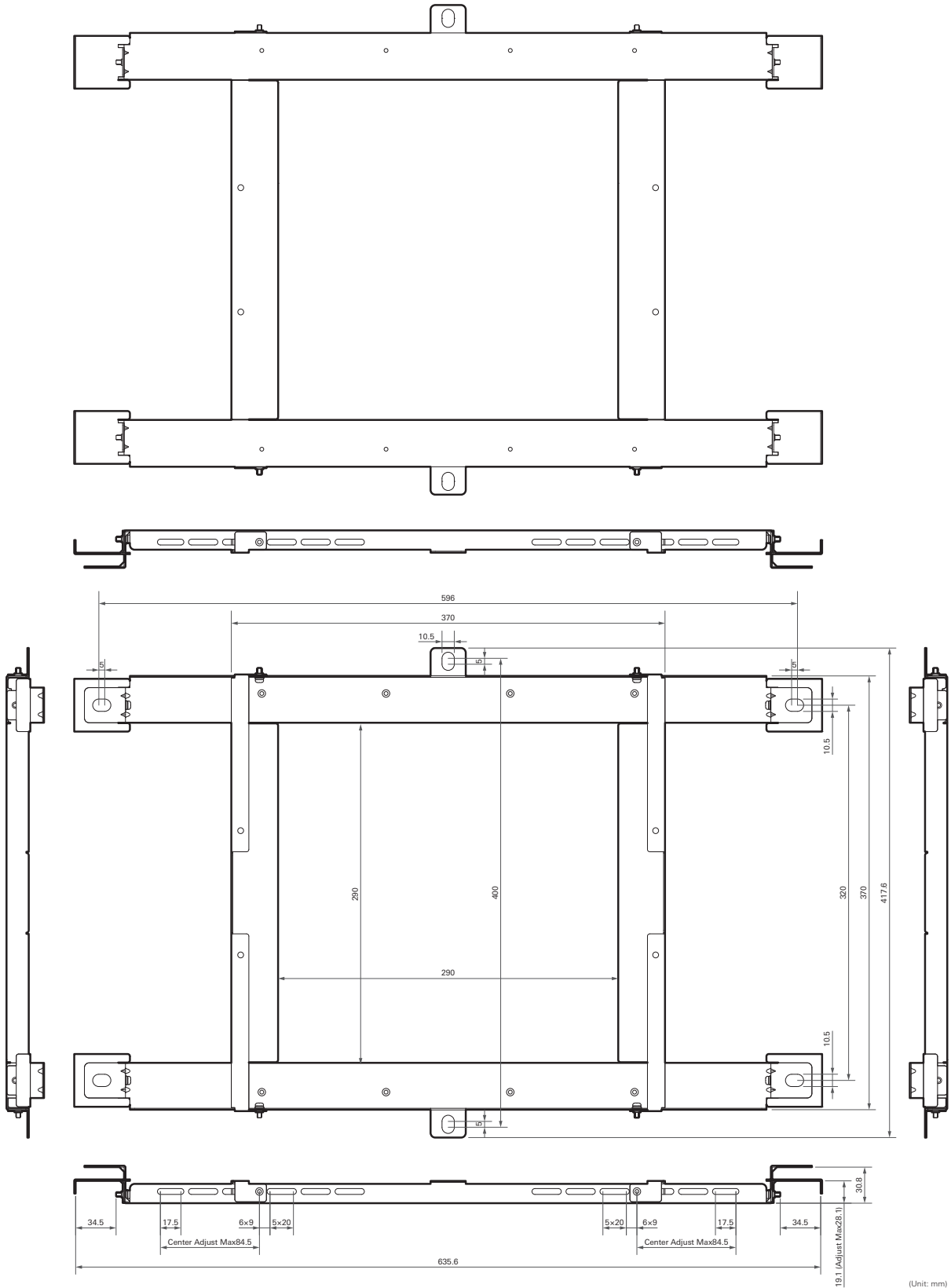

(Unit: mm)

# Specifications

## ATND1061LK

### General

<b>Power requirement</b>	+48 V DC (Audio-Technica LINK)
<b>Power consumption</b>	Max. 5.2 W
<b>Operation temperature range</b>	0°C to 40°C (32°F to 104°F)
<b>Operation humidity range</b>	25% to 85% (Non condensing)
<b>Dimensions</b>	227.5 mm (9.0") × 227.5 mm (9.0") × 30 mm (1.2") (W × D × H)
<b>Weight</b>	1,243 g (44 oz)
<b>Plenum rating</b>	UL 2043

### Microphone

<b>Beam width</b>	90°
<b>Polar pattern</b>	Beam pattern
<b>Frequency response</b>	60 Hz to 18,000 Hz
<b>Sensitivity</b>	-8 dBFS (1 kHz, 94 dBSPL)
<b>Dynamic range</b>	89 dB (A-weighted)
<b>Signal-to-noise ratio</b>	61.5 dB (A-weighted)
<b>Self-noise</b>	25 dBSPL (A-weighted)
<b>Maximum input sound level</b>	102 dBSPL

### Analog audio

<b>Frequency response</b>	20 Hz to 20 kHz (+1.0/-2.0 dB)
<b>Dynamic range</b>	100 dB (A-weighted)
<b>Signal-to-noise ratio</b>	80 dB (A-weighted)
<b>Headroom</b>	20 dB
<b>Residual noise</b>	-75.8 dBu (A-weighted)
<b>T.H.D.</b>	<0.1% (1 kHz, unity)
<b>Analog input</b>	MIC Maximum: -30 dBu MIC Unity: -50 dBu LINE Maximum: +12.2 dBu LINE Unity: -10 dBV, Switchable
<b>Analog output</b>	OUTPUT Maximum: +19.2 dBu OUTPUT Unity: +4 dBu/-10 dBV/-33 dBV, Switchable

## Specifications

### Other

<b>Network</b>	Audio-Technica Link: 100 Mbps IP control: 100 Mbps
<b>Digital audio</b>	Sampling rate: 48 kHz Bit depth: 24-bit
<b>Latency</b>	Microphone (CH1 to CH6): 47 msec Microphone (Auto Mix CH): 79 msec
<b>I/O connector</b>	Network/Audio-Technica Link: RJ-45 Analog input: Euroblock 3pin Analog output: Euroblock 3pin GPI: Euroblock 3pin
<b>Phantom power</b>	Analog input: 12 V
<b>Included accessories</b>	IR remote controller Surface mount adapter Screw (M4 × 50 mm) × 4 Flush mount adapter Flush mount cover Screw (M4 × 10 mm) × 12 Hole cover Nut × 4 Snap bushing × 2 Tile bridge A × 2 Tile bridge B × 2 Tile bridge C × 4 Seismic cable Zip tie Safety belt Euroblock connector × 3 Installation template

- For product improvement, the product is subject to modification without notice.

## ATND1061DAN

### General

<b>Power requirement</b>	PoE (IEEE 802.3af Class 0)
<b>Power consumption</b>	Max. 7 W
<b>Operation temperature range</b>	0°C to 40°C (32°F to 104°F)
<b>Operation humidity range</b>	25% to 85% (Noncondensing)
<b>Dimensions</b>	227.5 mm (9.0") × 227.5 mm (9.0") × 30 mm (1.2") (W × D × H)
<b>Weight</b>	1,250 g (44 oz)
<b>Plenum rating</b>	UL 2043

## Specifications

### Microphone

<b>Beam width</b>	90°
<b>Polar pattern</b>	Beam pattern
<b>Frequency response</b>	60 Hz to 18,000 Hz
<b>Sensitivity</b>	-8 dBFS (1 kHz, 94 dBSPL)
<b>Dynamic range</b>	89 dB (A-weighted)
<b>Signal-to-noise ratio</b>	61.5 dB (A-weighted)
<b>Self-noise</b>	25 dBSPL (A-weighted)
<b>Maximum input sound level</b>	102 dBSPL

### Analog audio

<b>Frequency response</b>	20 Hz to 20 kHz (+1.0/-2.0 dB)
<b>Dynamic range</b>	100 dB (A-weighted)
<b>Signal-to-noise ratio</b>	80 dB (A-weighted)
<b>Headroom</b>	20 dB
<b>Residual noise</b>	-75.8 dBu (A-weighted)
<b>T.H.D.</b>	<0.1% (1 kHz, unity)
<b>Analog input</b>	MIC Maximum: -30 dBu MIC Unity: -50 dBu LINE Maximum: +12.2 dBu LINE Unity: -10 dBV, Switchable
<b>Analog output</b>	OUTPUT Maximum: +19.2 dBu OUTPUT Unity: +4 dBu/-10 dBV/-33 dBV, Switchable

## Specifications

### Other

<b>Network</b>	Dante: 1 Gbps IP control: 100 Mbps
<b>Digital audio</b>	Sampling rate: 48 kHz Bit depth: 24-bit
<b>Latency</b>	Microphone (CH1 to CH6): 47 msec Microphone (Auto Mix CH): 79 msec Dante: Min. 250 usec, Max. 5 msec
<b>I/O connector</b>	Network/Dante: RJ-45 Analog input: Euroblock 3pin Analog output: Euroblock 3pin GPI: Euroblock 3pin
<b>Phantom power</b>	Analog input: 12 V
<b>Included accessories</b>	IR remote controller Surface mount adapter Screw (M4 × 50 mm) × 4 Flush mount adapter Flush mount cover Screw (M4 × 10 mm) × 12 Hole cover Nut × 4 Snap bushing × 2 Tile bridge A × 2 Tile bridge B × 2 Tile bridge C × 4 Seismic cable Zip tie Safety belt Euroblock connector × 3 Installation template

- For product improvement, the product is subject to modification without notice.

# Polar pattern / Frequency response

## Polar pattern

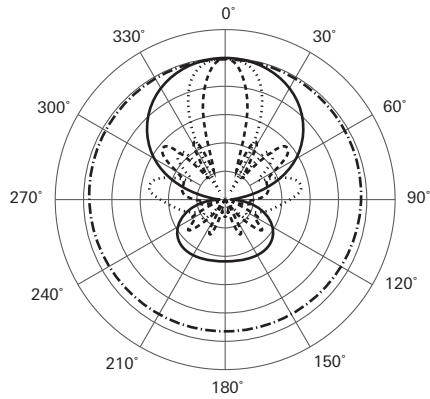

LEGEND

--- · ---	200 Hz	SCALE IS 5 DECIBELS PER DIVISION
—	1 kHz	
·····	5 kHz	
-----	8 kHz	

## Frequency response

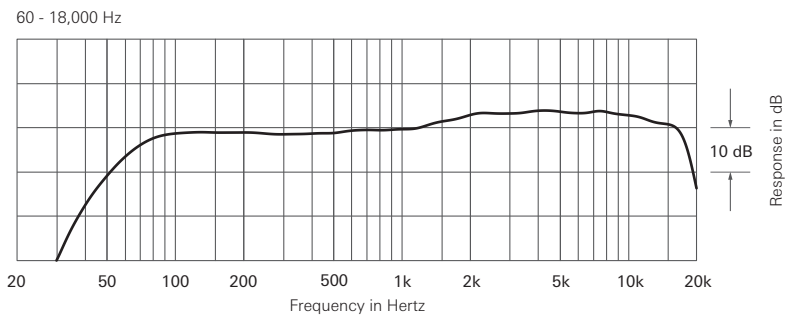

LEGEND

—	0°, 50 cm
---	-----------



# Trademarks

- Microsoft<sup>®</sup> and Windows<sup>®</sup> are registered trademarks of Microsoft Corporation in the United States and/or other countries.
- Microsoft Windows operating system is indicated in its abbreviated form as Windows.
- macOS and Safari are trademarks of Apple Inc., registered in the U.S. and other countries.
- Google Chrome is a trademark of Google LLC.
- Firefox is a trademark of the Mozilla Foundation in the U.S. and other countries.
- Other company names and product names shown in this manual are trademarks or registered trademarks of their respective companies.

# Audio-Technica Beamforming Array Microphone ATND1061DAN Signal Diagram

→ Audio data  
→ Control data

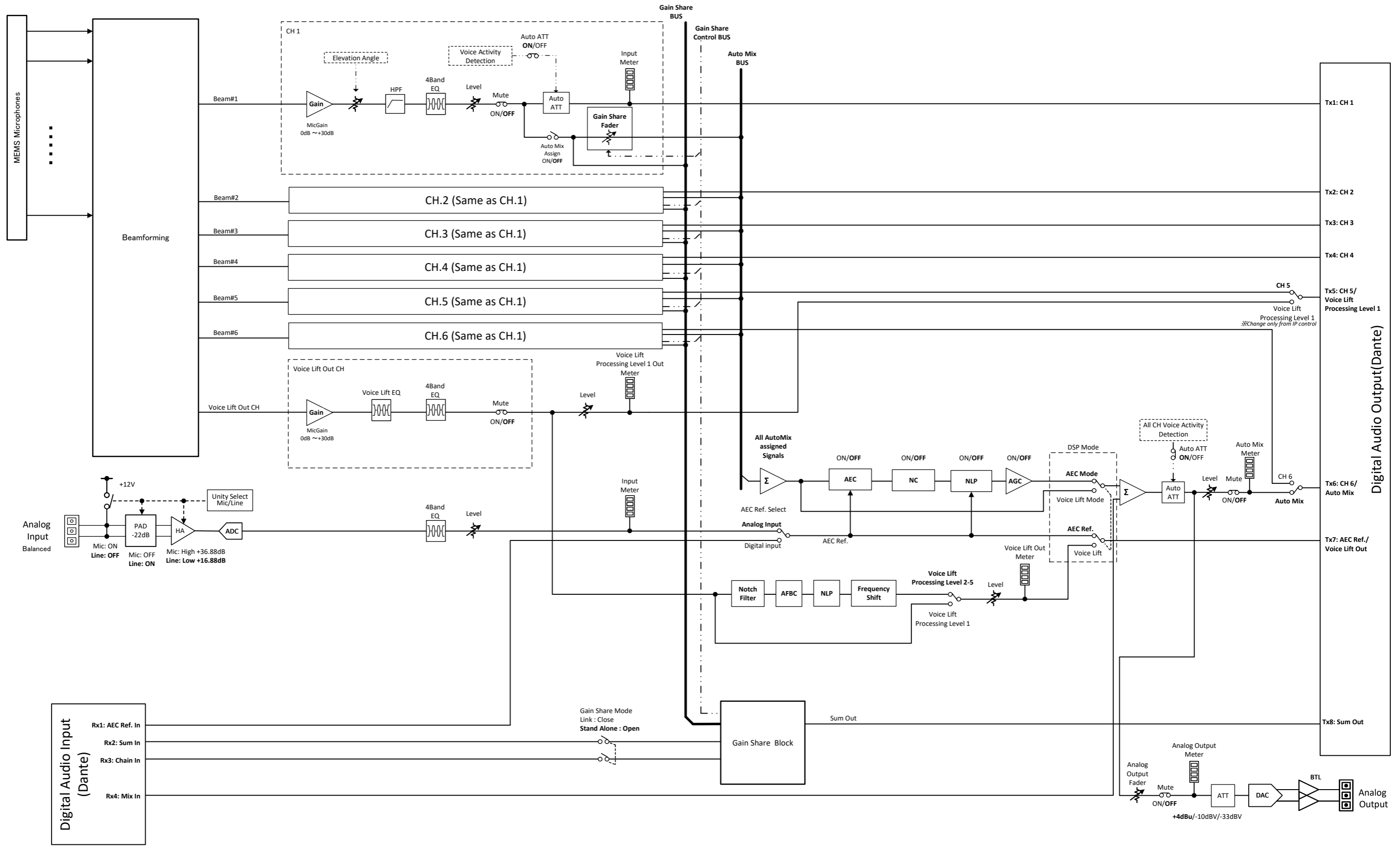

# Audio-Technica Beamforming Array Microphone ATND1061LK Signal Diagram

————> Audio data  
- - - -> Control data

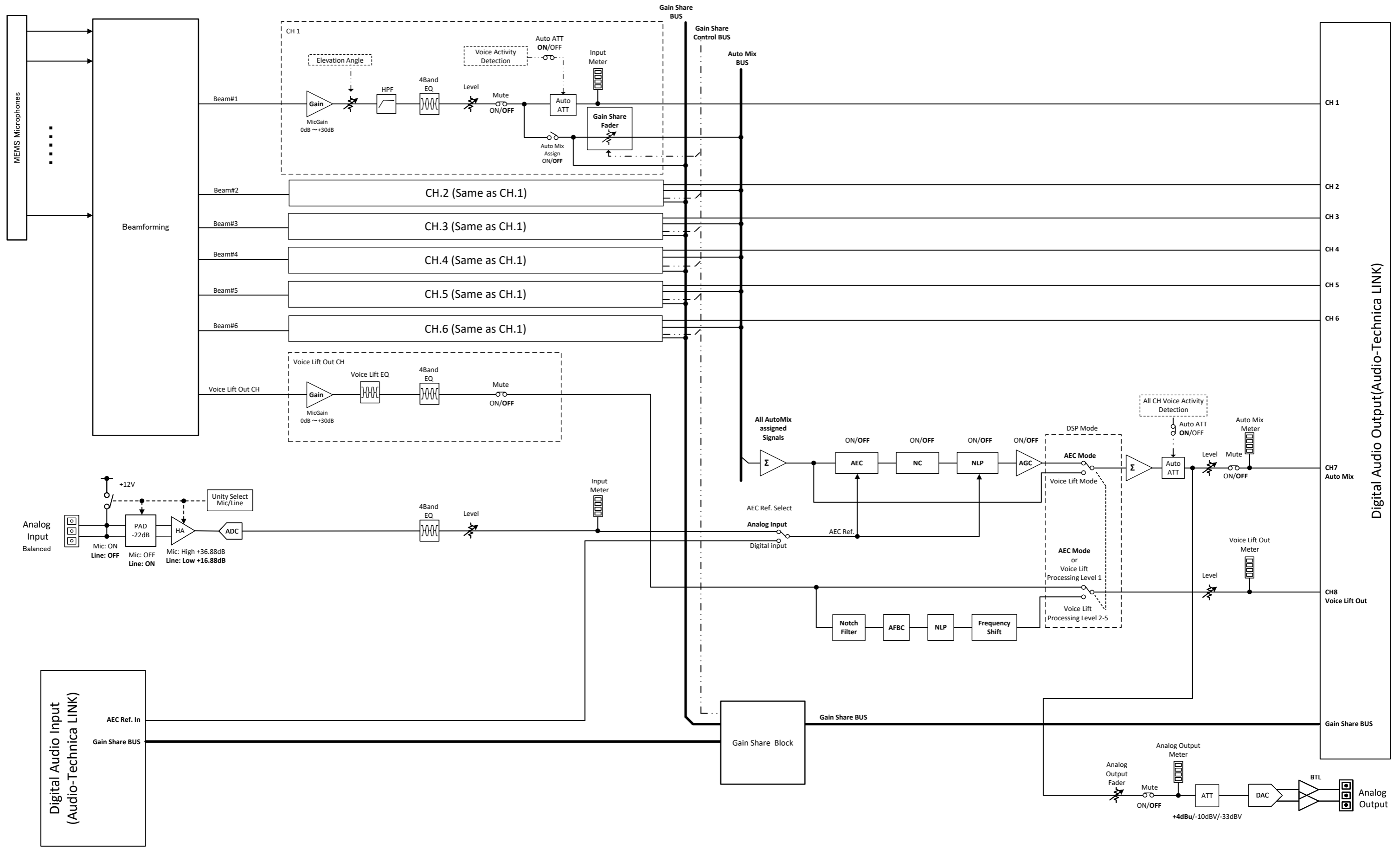

Digital Audio Output (Audio-Technica LINK)

CH 1  
CH 2  
CH 3  
CH 4  
CH 5  
CH 6  
CH 7 Auto Mix  
CH 8 Voice Lift Out  
Gain Share BUS

**Analog Input**  
Balanced

+12V

Unity Select Mic/Line

PAD -22dB

Mic: ON Line: OFF

Mic: OFF Line: ON

Mic: High +36.88dB Line: Low +16.88dB

HA

ADC

4Band EQ

Level

Input Meter

**Digital Audio Input (Audio-Technica LINK)**

AEC Ref. In

Gain Share BUS

Analog Output Meter

Analog Output Fader

Mute ON/OFF

ATT

DAC

BTL

Analog Output

+4dBu/-10dBV/-33dBV

**株式会社オーディオテクニカ**

〒194-8666 東京都町田市西成瀬2-46-1  
[www.audio-technica.co.jp](http://www.audio-technica.co.jp)

**Audio-Technica Corporation**

2-46-1 Nishi-naruse, Machida, Tokyo 194-8666, Japan  
[www.audio-technica.com](http://www.audio-technica.com)  
©2023 Audio-Technica Corporation  
Global Support Contact: [www.at-globalsupport.com](http://www.at-globalsupport.com)

142700180-02-05 ver.1 2022.02.01  
ver.5 2023.12.15