



**AT-CLM7000TX
AT-CLM7000TSX
AT-CLM7700TX
AT-CLM7700TSX**

User Manual / Infrared Wireless Microphone

audio-technica

Thank you for purchasing this Audio-Technica product. Before using the product, please read through the Quick Start Guide, as well as this user manual when necessary, to ensure that you can use the product correctly.

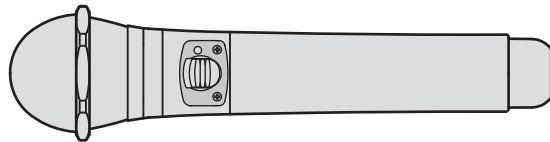

- Light, compact short-type microphone
- Power-saving design that has 3 levels of infrared output (ECO/LO/HI) for different room sizes
- With up to 10 hours of continuous use (in ECO mode) optimal for karaoke service
- Channels available for up to 4 microphones in the same room
- High sound quality, dynamic microphone unit
- Microphone unit assembly and grip low-assembly can be quickly exchanged
- Each microphone has two available channels*
 - * Channels can be identified by the color of the power indicator lamp. Thin channel identification rings are also supplied.

* This product must be used in combination with an Audio-Technica infrared wireless receiver and battery charger that are sold separately. Visit our web site for information on compatible models.

Important information

Warning:

- To prevent fire or shock hazard, do not expose this apparatus to rain or moisture.

Caution:

- Do not expose this apparatus to drips or splashes.
- To avoid electric shock, do not open the cabinet.
- Refer servicing to qualified personnel only.
- Do not expose this apparatus to excessive heat such as that generated by sunshine, fire or other heat sources.
- Do not subject this apparatus to strong impact.
- Do not place any objects filled with liquids, such as vases, on this apparatus.
- To prevent fire, do not place any naked flame sources (such as lighted candles) on this apparatus.
- Do not install this apparatus in a confined space such as a bookcase or similar unit.
- Install this apparatus only in the places with good ventilation.

Battery caution:

- Keep batteries out of the reach of children.
- Observe correct polarity as marked.
- Do not expose the battery to excessive heat such as sunshine, fire or the like.
- Always consider the environment issues and follow local regulations when disposing of batteries.
- Remove depleted battery immediately.
- Danger of explosion if battery is incorrectly replaced. Replace only with the same or equivalent type.
- Recommend to use audio-technica original Ni-MH batteries.
- Do not use new batteries and old one at the same time.
- Do not use different batteries type or model.
- Do not use a leaking battery. If battery leakage occurs, avoid contact with skin. If contact occurs, immediately wash thoroughly with soap and water.
- If battery leakage comes into contact with your eyes, immediately flush with water and seek medical.

FCC Notice

Warning:

This device complies with Part 15 of the FCC Rules. Operation is subject to the following two conditions: (1) This device may not cause harmful interference, and (2) this device must accept any interference received, including interference that may cause undesired operation.

Caution:

You are cautioned that any changes or modifications not expressly approved in this manual could void your authority to operate this equipment.

Note:

This equipment has been tested and found to comply with the limits for a Class B digital device, pursuant to part 15 of the FCC Rules. These limits are designed to provide reasonable protection against harmful interference in a residential installation. This equipment generates, uses and can radiate radio frequency energy and, if not installed and used in accordance with the instructions, may cause harmful interference to radio communications. However, there is no guarantee that interference will not occur in a particular installation.

If this equipment does cause harmful interference to radio or television reception, which can be determined by turning the equipment off and on, the user is encouraged to try to correct the interference by one or more of the following measures:

- Reorient or relocate the receiving antenna.
- Increase the separation between the equipment and receiver.
- Connect the equipment into an outlet on a circuit different from that to which the receiver is connected.
- Consult the dealer or an experienced radio/TV technician for help.

Notes on use

- Be sure to also read the connecting device's user manual before use.
- Do not cover the infrared emitter with your hand.
- Do not grip or twist the infrared emitter. Doing so may result in a malfunction.
- The distance the infrared light can reach varies by the color and material of the walls, ceiling, and/or floor.
- Noise may occur irrespective of the distance.
 - In such a case, reattach the receiver unit in a different place.
- Battery level is not correctly indicated when commercial-grade AA alkaline dry cells are used.
- The rechargeable battery is not supplied charged.
- When charged for the first time or after not having been used for a long time, the rechargeable battery may not last as long. In such a case, repeat the charge-discharge cycle several times to improve charging performance.
- To protect the rechargeable battery, charge it at least once every 6 months when keeping it in storage for an extended period of time. If too much time passes between charges, the rechargeable battery may not last as long or may no longer be able to be charged.
- Repeated charging without using up the charge in the rechargeable battery causes a memory effect where battery drain occurs irrespective of the charged state. Start charging only after using up the charge, which is when the indicator lamp turns off. If the problem still persists, the rechargeable battery may have reached the end of its life. In such a case, replace it with a new rechargeable battery.
- Repeated charging of the rechargeable battery causes the maximum capacity of the battery to drop. When the effective battery time starts getting shorter, a battery replacement is recommended.
- The rechargeable battery may have white powder-like adhesion. This does not indicate a malfunction. Wipe it off completely using dry cloth and use the rechargeable battery again.

Part names and functions

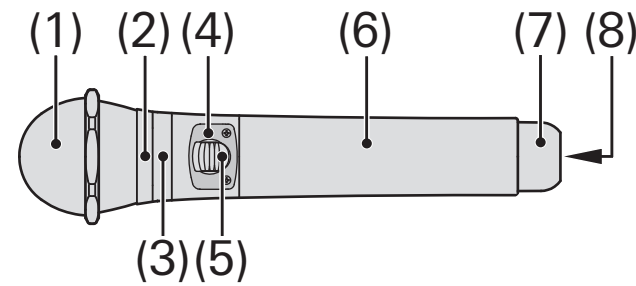

Grip removed

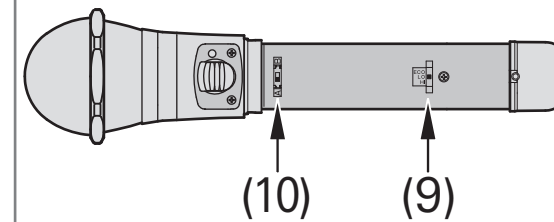

(1) Head case

(2) Head case screw

(3) Ring nameplate

AT-CLM7000TX / AT-CLM7000TSX: Black
AT-CLM7700TX / AT-CLM7700TSX: Silver

(4) Power indicator lamp

Displays the battery level when the microphone is turned on.

Lit : Ready for use

Blinking / Not lit: Charge the device.

* Indication colors

AT-CLM7000TX / AT-CLM7000TSX: Yellow (A channel)

: Green (B channel)

AT-CLM7700TX / AT-CLM7700TSX: Red (A channel)

: Blue (B channel)

* The indicated charge level is for reference only.

* When the power indicator lamp is blinking, the reception range may be reduced, which can result in noise or interruption.

(5) Power switch

Slide the switch upward to turn on the power.

(6) Grip

(7) Infrared emitter

(8) Charging terminal

(9) Output control switch

Use this switch to change the infrared output setting.

(10) Channel (ch) switch

Use this switch to change the channel (carrier frequency).

Inserting the battery/batteries

In case of an emergency, this product can be used with two commercial-grade AA alkaline dry cells. Battery level is not correctly indicated in this case.

Never charge alkaline batteries.

1 Turn off the power.

2 Turn the grip counter-clockwise to remove it.

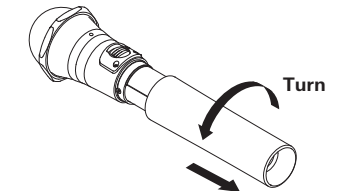

3 Turn the head case downward and insert the battery/batteries from the ⊖ side.

When using the dedicated nickel-metal hydride battery

* When using AA alkaline dry cells
* Insert one at a time.

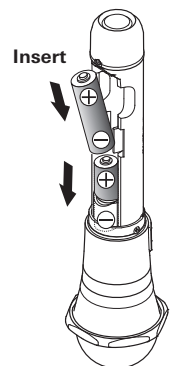
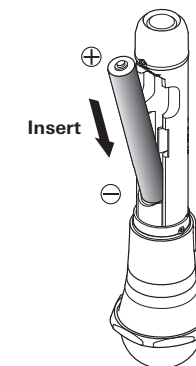

4 Slip the grip over the microphone and turn it clockwise until it comes to a stop.

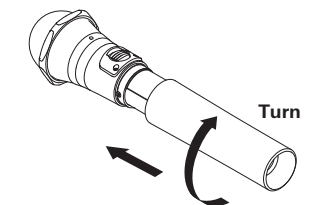

5 Turn on the power switch, and if the power indicator lamp turns on, the microphone is functioning correctly.

* A blinking or non-lit power indicator lamp indicates battery drain.

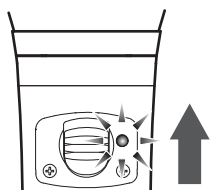

Using the product

- * Read the user manual for Audio-Technica infrared wireless receiver sold separately.
- * Set the channel and attach the channel identification ring before use.

- Charge this product.
- Check the receiver's output switch setting (Microphone - Line).
- Turn on the power to the receiver.
 - * You will not hear any sound for about 1 second after turning on the power.
- Turn on the power to this product.
- After checking that sound is produced, adjust the volume using your device or receiver.

Switching the output setting

To adjust the transmission range, slide the output control switch to change the setting.

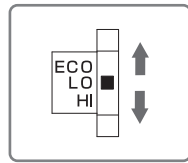

- * ECO: Low output, LO: Standard, HI: High output
- * The continuous use time changes along with any change to the output setting.
- * Set to "LO" by factory default.

Switching the channel

To change the channel, turn off the power and slide the channel switch.

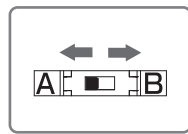

- * Changing the channel while the power is turned on will cause noise.
- * Set to "A channel" by factory default.

Attaching the channel identification ring

1 Turn the grip counter-clockwise to remove it.

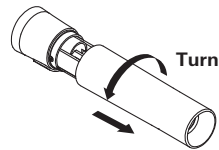

2 Attach the channel identification ring according to the channel.

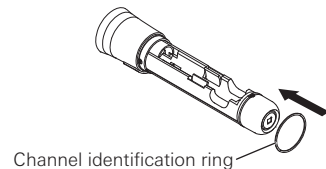

3 Slip the grip over the microphone and turn it clockwise until it comes to a stop.

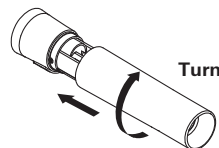

Transmission frequency

The frequencies corresponding to the channels for this product are shown in the chart below.

Microphone	Channel	Frequency	Receiver channel*
AT-CLM7000TX / TSX	A	2.06 MHz	1 ch
AT-CLM7000TX / TSX	B	2.56 MHz	2 ch
AT-CLM7700TX / TSX	A	3.20 MHz	3 ch
AT-CLM7700TX / TSX	B	3.70 MHz	4 ch

* For AT-CR7000 and AT-CR9000

Transmission range

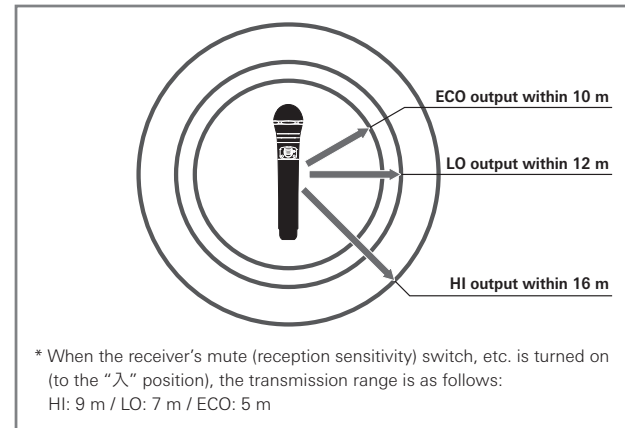

- * The above transmission range is an approximate range under conditions where there is open space and no obstruction between this product and the receiver.
- * The transmission range can vary depending on the ambient environment and receiver settings.
- * Any obstruction between the product and the receiver may cause noise or sound disruption even within the above transmission range.

Wireless system

- * Read the user manual for Audio-Technica infrared wireless receiver sold separately.

When using two of this product at the same time, set one of the channels to A and the other to B.

- * Two wireless systems with the same channel (frequency) cannot be used at the same time.
- * Maintain a distance of at least 1.5 m between this product and the receiver unit during use. Otherwise malfunction and/or noise may occur.
- * Use this product away from any nearby TVs or other digital equipment. Otherwise transmission may be affected by radio waves and/or noise.

Example of use

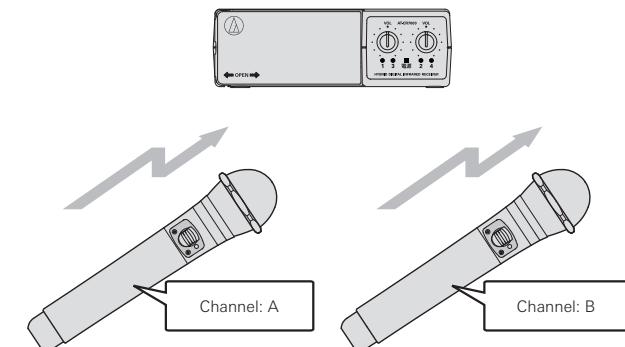

Charging the battery

- * Read the user manual for Audio-Technica battery charger sold separately.

Example of use

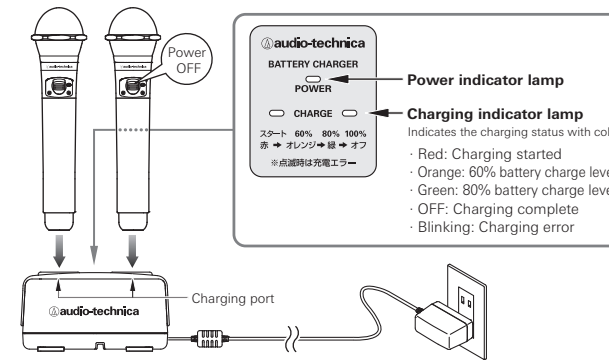

- Turn off the power and connect this product to the charging port.

- * Connect this product to the charger and if the charging indicator lamp blinks, there may be an error. Try again after turning the charger off and on.
- * When the product is connected to the charging port while it is powered on, the product turns off automatically and charging starts. (Auto OFF function)

- While a device is being charged, the charging indicator lamp changes according to the charging status. (Red → Orange → Green)
- Charging is complete when the charging indicator lamp turns off.

- * Charging will complete in **about 5.5 hours**.
- * The rechargeable battery in this product lasts about 1 year with proper use or for about 750 charging cycles.
- * The indicated charge level is for reference only. Use this product after it is fully charged (charging indicator lamp turns off) whenever possible.
- * If only a small amount of charge had been drained from the rechargeable battery, the charging quickly completes automatically.

Troubleshooting

Use the following tips as a reference. If the problem persists, please contact your local Audio-Technica dealer.

Q. The product does not turn on.

A: Check that the product is charged.

Q. Receiver is not responding.

A1: Check for any obstruction between this product and the receiver unit.
A2: Check the distance between this product and the receiver unit to make sure that they are not too far apart.

Q. Battery drains quickly after full charge.

A: Battery may have developed a memory effect.
Turn on the power switch and after leaving this product for more than 5 hours, turn off the power switch and try charging again.
* If the problem still persists after performing the above operation, the rechargeable battery may have reached the end of its life (750 times of charging). In such a case, replace it with a new rechargeable battery.

Specifications

Type	: Dynamic	
Polar pattern	: Cardioid	
Modulation method	: FM frequency modulation	
Tone signal	: 35.7 kHz	
Carrier frequency	: A channel: 2.06 MHz, B channel: 2.56 MHz (when AT-CLM7000TX / AT-CLM7000TSX is used) : A channel: 3.20 MHz, B channel: 3.70 MHz (When AT-CLM7700TX / AT-CLM7700TSX is used)	
Infrared wavelength	: 870 ±30 nm	
Power supply	: 2.4 to 3 V DC (when using the dedicated nickel-metal hydride battery or two AA alkaline dry cells)	
Continuous use time*	: When using the dedicated nickel-metal hydride battery Approx. 10 hours (ECO mode) Approx. 7.5 hours (LO mode) Approx. 4.5 hours (HI mode) : When using AA alkaline dry cells Approx. 8 hours (ECO mode) Approx. 5.5 hours (LO mode) Approx. 3 hours (HI mode)	

Operating temperature range	: 5°C to 40°C
Dimensions	: 56 mm × 223 mm (Head dia. × Full length)
Weight	: Approx. 275 g (including dedicated nickel-metal hydride battery)
Accessories	: Dedicated nickel-metal hydride battery RB3UTG (1900 mAh) (pre-installed in the product) : Channel identification ring AT-CLM7000TX / AT-CLM7000TSX: Yellow, Green AT-CLM7700TX / AT-CLM7700TSX: Red, Blue

* The above figures depend on operating conditions. The product is subject to modification without notice for product improvement.