

6.5" woofer, 3.0" tweeter 2-way 3-speaker system



Speaker System (2pcs per 1set)

AT-KSP72 (US)

- 16 cm (6.5") woofer, 7.7 cm (3.0") tweeter
2-way 3-speaker system
- Rated input: 70 W (JEITA)
- Maximum input: 200 W (JEITA)
- Speaker unit protection circuit (tweeter) provided

► Dimensions

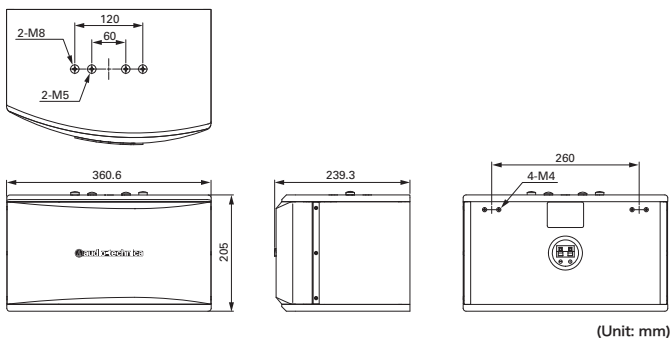

· Specifications

Element	Bass reflex (phase inversion), 2-way 3-speaker system
Speaker unit	16 cm (6.5") woofer, 7.7 cm (3.0") tweeter
Frequency response	60 to 20,000Hz
Rated input	70 W (JEITA)*
Maximum input	200 W (JEITA)*
Nominal impedance	8 ohms
Sensitivity	89 dB (JEITA)*
Dimensions	205 mm (8.07") 360.6 mm (14.20") × 239.3 mm (9.42") (H × W × D)
Weight	Approx. 6.2 kg (13.7 lb) (1 unit)

This product is recommended to be attached by construction workers.

* JEITA is the standard of the Japan Electronics and Information Technology Industries Association. The product is subject to modification without notice for product improvement.

Frequency/impedance characteristics chart

